



# Certificat d'homologation

**CDN/E044/-96 (Rév. 22)**

## Acceptation de la conception de colis de transport de l'étranger

**n° USA/9036/B(U)-96 (Rév. 17)**

La Commission canadienne de sûreté nucléaire a procédé à l'homologation du modèle de colis décrit plus loin en vertu de l'alinéa 21(1)(h) de la *Loi sur la sûreté et la réglementation nucléaires* et de l'article 10(1) du *Règlement sur l'emballage et le transport des substances nucléaires* (2015) du Canada et du Règlement de l'AIEA, Édition de 2012, *Règlement de transport des matières radioactives* de l'Agence internationale de l'énergie atomique.

### **INSCRIPTION DE L'USAGE DU COLIS**

Toute personne qui prévoit utiliser la présente autorisation pour la première fois doit s'inscrire par écrit auprès de la Commission canadienne de sûreté nucléaire et attester qu'elle possède les instructions nécessaires pour préparer le colis pour fins d'expédition.

### **IDENTIFICATION DU COLIS**

Concepteur : **Source Production & Equipment Co., Inc.**

Marque/Modèle : **Dispositif de changement de source C-1**

Modes de transport : **aérien, maritime, routier, ferroviaire**

### **MARQUE D'IDENTIFICATION**

Le colis porte la marque d'identification <<**USA/9036/B(U)-96**>> de l'autorité compétente.

### **DESCRIPTION DU COLIS**

L'emballage, selon les dessins nos B322000 (Rév. 3) et B311000, feuilles 2 et 5, (Rév. 2); ci-joint, comprend une boîte rectangulaire d'acier de 3 mm d'épaisseur, mesurant 190 mm de largeur sur 190 mm de profondeur sur 230 mm de hauteur et un suremballage d'un baril rempli de mousse de polyuréthane. Le récipient intérieur comprend un blindage d'uranium appauvri muni de deux tubes de Zircaloy en forme de "J" à fond fermé, qui peuvent recevoir chacun un assemblage de source sous forme spéciale.



La configuration du colis est la suivante :

|            |              |                        |                         |
|------------|--------------|------------------------|-------------------------|
| Forme :    | <b>Fût</b>   | Blindage :             | <b>Uranium Appauvri</b> |
| Masse :    | <b>45 kg</b> | Enveloppe extérieure : | <b>Acier</b>            |
| Longueur : | <b>n/a</b>   | Hauteur :              | <b>521 mm</b>           |
| Largeur :  | <b>n/a</b>   | Diamètre :             | <b>368 mm</b>           |

## **CONTENU RADIOACTIF AUTORISÉ**

Le colis peut contenir un maximum de deux sources scellées dont l'activité de sortie\* combinée ne doit pas dépasser 11.1 TBq (300 Ci) d'iridium 192, selenium 75 ou ytterbium 169, encapsulé dans une source scellée possédant une homologation pour les sources radioactives sous forme special valide. Les assemblages de sources scellées autorisées sont :

- i) modèle de source nos A424-9 et 969 de QSA Global;
- ii) modèle de source nos B-16F, B-16T, G-1T, G-1F, G-3F, G-40F, G-40T, G-60, T-5 and T-5F de SPEC; et
- iii) Modèle INC 32 de Industrial Nuclear Company.

\* L'activité de sortie est déterminée en mesurant l'activité (en curie) de la source à un mètre de distance dérivé de la façon suivante : 0.48 R/h-Ci à 1 mètre pour l'iridium 192.

## **SYSTÈME DE GESTION**

Le système de gestion visant la conception, la fabrication, les épreuves, l'établissement des documents, l'utilisation, l'entretien et l'inspection du colis doit être conforme aux :

- Certificat de l'étranger n° USA/9036/B(U)-96 (Rév. 17)
- Règlement sur l'emballage et le transport des substances nucléaires (2015)

## **EXPÉDITION**

La préparation du colis pour fins d'expédition doit être conforme aux :

- Certificat de l'étranger n° USA/9036/B(U)-96 (Rév. 17)
- Règlement sur l'emballage et le transport des substances nucléaires (2015)

Le présent certificat n'est valide qu'au Canada.

E. Lemoine  
Fonctionnaire désigné en vertu de l'alinéa 37(2)(a) de la  
Loi sur la sûreté et la réglementation nucléaires



## **NOTES**

Certificat de l'étranger n° USA/9036/B(U)-96 (Rev. 17) ci-joint.

Révision 20 : le 25 octobre 2016. Certificat délivré afin d'incorporer la révision 16 du certificat de l'étranger.

Révision 21 : le 1 octobre 2018. Certificat modifié pour ajouter un modèle d'assemblage de source scellée.

Révision 22 : le 25 octobre 2022. Renouvellement du certificat.

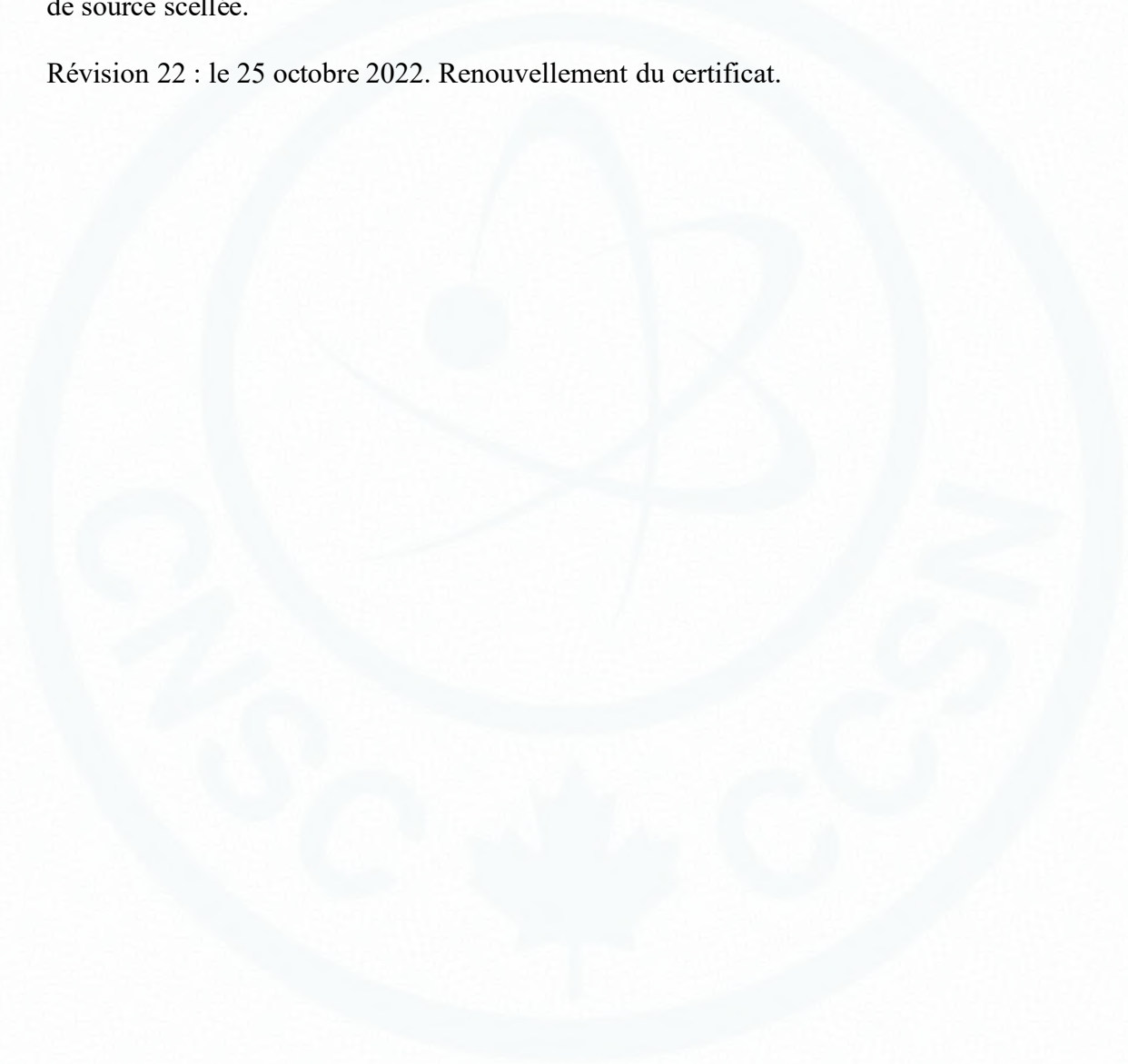



|                    |             |
|--------------------|-------------|
| CONTROLLED COPY NO |             |
| REV                | DESCRIPTION |
| DATE               | APPROVED    |

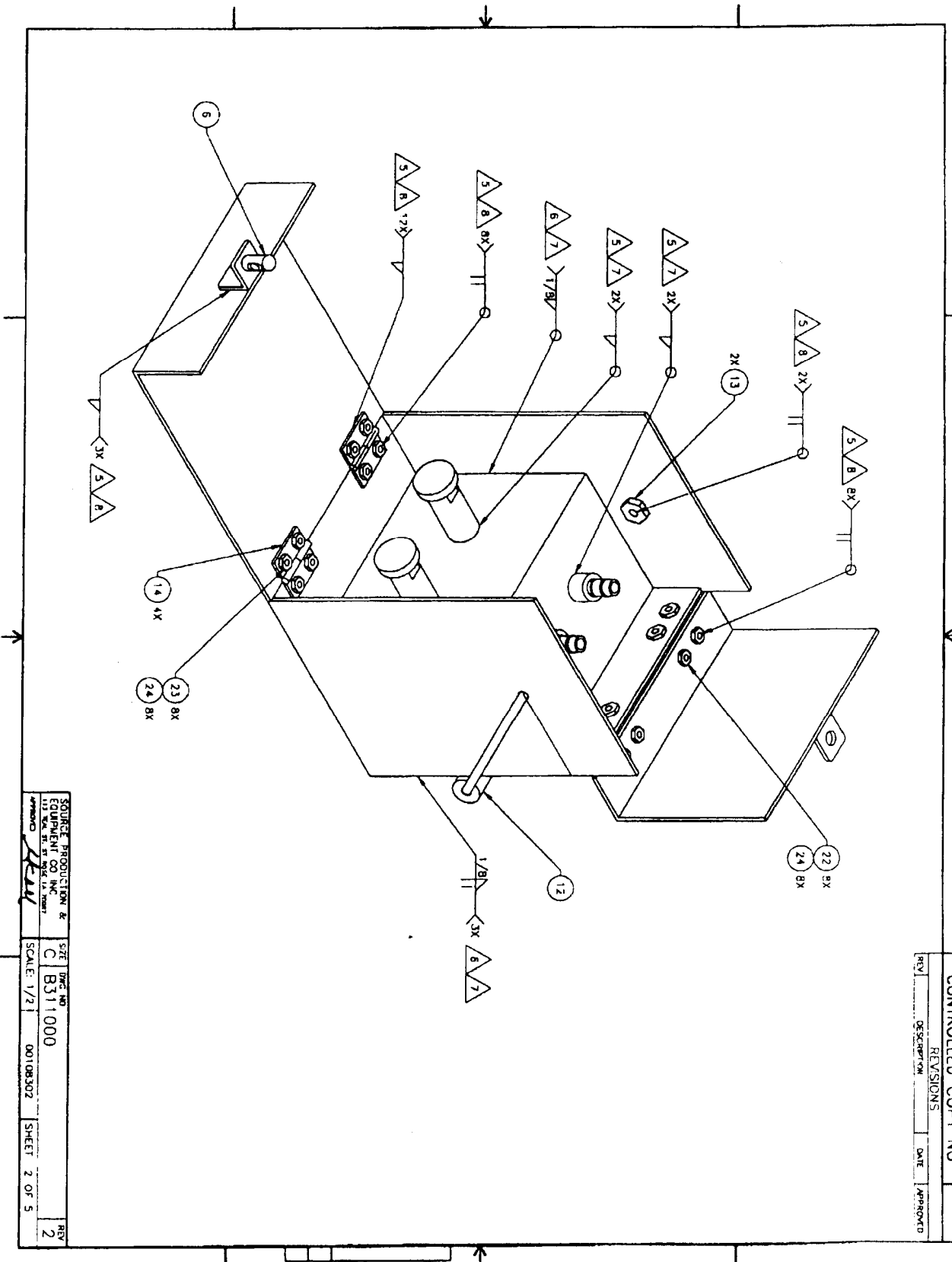

|   |          |
|---|----------|
| SOURCE PRODUCTION & EQUIPMENT CO. INC.<br>111 N. W. 11th St. Ft. Lauderdale, Fla. 33304 |          |
| SIZE  | DRG. NO. |
| C   | B311000  |
| SCALE: 1/2  | 00108302 |
| SHEET   | 2 OF 5   |
| REV   | 2        |

|                     |           |
|---------------------|-----------|
| CONTROLLED COPY NO. |           |
| REV                 | REVISIONS |
| DESCRIPTION         | DATE      |
| APPROVED            |           |

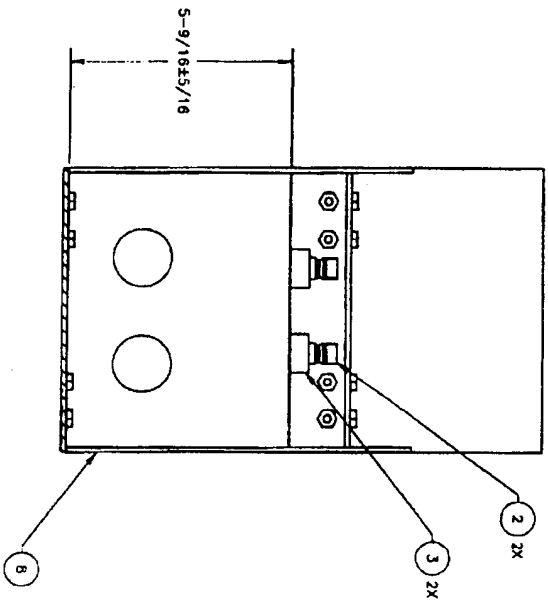

SECTION B-B  
SEE SHEET 3  
HANDLE AND HIDDEN  
LINES NOT SHOWN

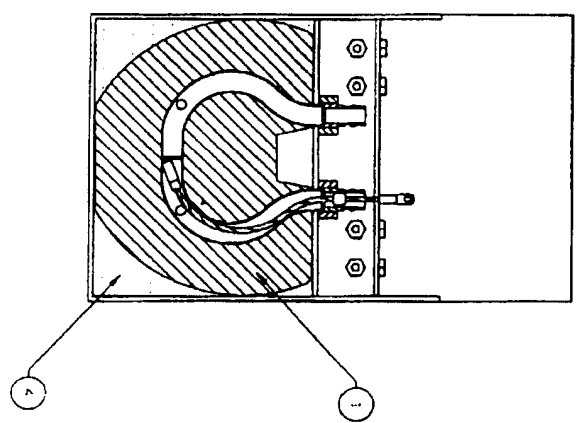

SECTION C-C  
SEE SHEET 3  
HANDLE AND HIDDEN  
LINES NOT SHOWN

|                                  |             |
|----------------------------------|-------------|
| EQUIPMENT PRODUCTION & EQUIPMENT |             |
| 113 7th St SE                    | APT. 1000   |
| APPROVED                         |             |
| STATE DWG. NO.                   | C 1 B311000 |
| SCALE: 1/2                       | 00108302    |
| SHEET                            | 5 OF 5      |
| REV                              | 2           |



U.S. Department  
of Transportation

Pipeline and  
Hazardous Materials  
Safety Administration

East Building, PHH-23  
1200 New Jersey Ave, SE  
Washington, D.C. 20590

**COMPETENT AUTHORITY CERTIFICATION FOR A  
TYPE B (U)  
RADIOACTIVE MATERIALS PACKAGE DESIGN  
CERTIFICATE USA/9036/B(U)-96, REVISION 17**

The Competent Authority of the United States certifies that the radioactive material package design described in this certificate satisfies the regulatory requirements for a Type B(U) package as prescribed in the regulations of the International Atomic Energy Agency<sup>1</sup> and the United States of America<sup>2</sup> The package design is approved for use within the United States for import and export shipments made in accordance with applicable international and domestic transport regulations.

1. Package Identification - C-1.
2. Package Description and Authorized Radioactive Contents - as described in U.S. Nuclear Regulatory Commission Certificate of Compliance No. 9036, Revision 14 (attached).
3. General Conditions -
  - a. Each user of this certificate must have in his possession a copy of this certificate and all documents necessary to properly prepare the package for transportation. The user shall prepare the package for shipment in accordance with the documentation and applicable regulations.
  - b. Each user of this certificate, other than the original petitioner, shall register his identity in writing to the Office of Engineering and Research, (PHH-23), Pipeline and Hazardous Materials Safety Administration, U.S. Department of Transportation, Washington D.C. 20590-0001.

---

<sup>1</sup> "Regulations for the Safe Transport of Radioactive Material, 2012 Edition, No. SSR-6" published by the International Atomic Energy Agency (IAEA), Vienna, Austria.

<sup>2</sup> Title 49, Code of Federal Regulations, Parts 100-199, United States of America.

**CERTIFICATE USA/9036/B(U)-96, REVISION 17**

- c. This certificate does not relieve any consignor or carrier from compliance with any requirement of the Government of any country through or into which the package is to be transported.
  - d. Records of Management System activities required by Paragraph 306 of the IAEA regulations<sup>1</sup> shall be maintained and made available to the authorized officials for at least three years after the last shipment authorized by this certificate. Consignors in the United States exporting shipments under this certificate shall satisfy the applicable requirements of Subpart H of 10 CFR 71.
4. Marking and Labeling - The package shall bear the marking USA/9036/B(U)-96 in addition to other required markings and labeling.
5. Expiration Date - This certificate expires on October 31, 2026. Previous editions which have not reached their expiration date may continue to be used.

This certificate is issued in accordance with paragraph(s) 810 of the IAEA Regulations and Section 173.471 of Title 49 of the Code of Federal Regulations, in response to the October 5, 2021 petition by Source Production and Equipment Company, Inc., St. Rose, LA, and in consideration of other information on file in this Office.

Certified By:



William Schoonover  
Associate Administrator for Hazardous  
Materials Safety

October 06, 2021  
(DATE)

Revision 17 - Issued to endorse U.S. Nuclear Regulatory Commission  
Certificate of Compliance No. 9036, Revision 14.



**CERTIFICATE OF COMPLIANCE  
FOR RADIOACTIVE MATERIAL PACKAGES**

| 1. | a. CERTIFICATE NUMBER | b. REVISION NUMBER | c. DOCKET NUMBER | d. PACKAGE IDENTIFICATION NUMBER | PAGE | PAGES |
|----|-----------------------|--------------------|------------------|----------------------------------|------|-------|
|    | 9036                  | 14                 | 71-9036          | USA/9036/B(U)-96                 | 1 OF | 3     |

2. PREAMBLE

- a. This certificate is issued to certify that the package (packaging and contents) described in Item 5 below meets the applicable safety standards set forth in Title 10, *Code of Federal Regulations*, Part 71, "Packaging and Transportation of Radioactive Material."
- b. This certificate does not relieve the consignor from compliance with any requirement of the regulations of the U.S. Department of Transportation or other applicable regulatory agencies, including the government of any country through or into which the package will be transported.

3. THIS CERTIFICATE IS ISSUED ON THE BASIS OF A SAFETY ANALYSIS REPORT OF THE PACKAGE DESIGN OR APPLICATION

- |  |  |
|--|--|
| a. ISSUED TO ( <i>Name and Address</i> )<br>Source Production and<br>Equipment Company, Inc.<br>113 Teal Street<br>St. Rose, LA 70087-9691 | b. TITLE AND IDENTIFICATION OF REPORT OR APPLICATION<br>Source Production and Equipment Company, Inc.<br>application dated February 28, 2001, as supplemented. |
|--|--|

4. CONDITIONS

This certificate is conditional upon fulfilling the requirements of 10 CFR Part 71, as applicable, and the conditions specified below.

5.

(a) Packaging

- (1) Model No.: C-1
- (2) Description

The packaging consists of a steel inner unit inside an outer overpack. The inner unit is a rectangular box approximately 9" high x 7.5" wide x 7.5" deep around a depleted uranium shield. All fittings and source locking components are protected and enclosed within the 1/8" carbon steel outer shell. The inner receptacle consists of a uranium shield equipped with two closed bottom Zircalloy or titanium "J" tubes, each of which may house one "pigtail type" special form source. The overpack is a 12-gallon, 20- or 22-gage steel drum partially filled with foam. The weight of the inner unit is 51 to 70 lbs. The weight of the overpack is 19 to 22 lbs. Up to 8 lbs. of ancillary equipment may be included within the overpack. The maximum gross weight of the package is 100 lbs.

(3) Drawings

The packaging is constructed in accordance with Source Production and Equipment Company, Inc., Drawing Nos. B322000, Rev. (3); B311000, Rev. (2); B311001, Rev. (1); and B311002, Rev. (0).

**CERTIFICATE OF COMPLIANCE  
FOR RADIOACTIVE MATERIAL PACKAGES**

| 1. | a. CERTIFICATE NUMBER | b. REVISION NUMBER | c. DOCKET NUMBER | d. PACKAGE IDENTIFICATION NUMBER | PAGE | PAGES |
|----|-----------------------|--------------------|------------------|----------------------------------|------|-------|
|    | 9036                  | 14                 | 71-9036          | USA/9036/B(U)-96                 | 2 OF | 3     |

5.(b) Contents

(1) Type and form of material

Iridium-192, Selenium-75, and Ytterbium-169 as sealed sources that meet the requirements of special form radioactive material.

(2) Maximum quantity of material per package

Two sealed sources with a combined activity not to exceed 300 curies (11.1 TBq) (output)

Output curies are determined by measuring the source output at 1 meter and expressing its activity in curies derived from the following: 0.48 R/(h-Ci) Iridium-192.

6. Tungsten shield pads, with dimensions up to approximately 2-inches diameter and ½-inch thick, may be welded to the inside surface of the source changer housing.
7. The nameplate shall be fabricated of materials capable of resisting the fire test of 10 CFR Part 71 and maintaining their legibility.
8. In addition to the requirements of Subpart G of 10 CFR Part 71:
  - (a) The package shall be prepared for shipment and operated in accordance with the Operating Procedures of Section 7.0 of the application, as supplemented; and
  - (b) The package shall meet the Acceptance Tests and be maintained in accordance with the Maintenance Program of Section 8.0 of the application, as supplemented.
9. The packaging authorized by this certificate is hereby approved for use under the general license provisions of 10 CFR 71.17.
10. Revision No. 13 of this certificate may be used until October 31, 2021.
11. Expiration date: October 31, 2026.

**CERTIFICATE OF COMPLIANCE  
FOR RADIOACTIVE MATERIAL PACKAGES**

| 1. | a. CERTIFICATE NUMBER | b. REVISION NUMBER | c. DOCKET NUMBER | d. PACKAGE IDENTIFICATION NUMBER | PAGE | PAGES |
|----|-----------------------|--------------------|------------------|----------------------------------|------|-------|
|    | 9036                  | 14                 | 71-9036          | USA/9036/B(U)-96                 | 3 OF | 3     |

REFERENCES

Source Production and Equipment Company, Inc., applications dated September 27, 2000, and February 28, 2001.

Supplements dated: April 11, and May 11, 2001; May 1, June 14, and June 23, 2006; May 26, 2011; May 31, 2016; and September 28, 2021.

FOR THE U.S. NUCLEAR REGULATORY COMMISSION

**John B.  
McKirgan**

Digitally signed by John B.  
McKirgan

Date: 2021.10.01 09:38:51 -04'00'

John McKirgan, Chief  
Storage and Transportation Licensing Branch  
Division of Fuel Management  
Office of Nuclear Material Safety  
and Safeguards

Date: October 1, 2021





East Building, PHH-23  
1200 New Jersey Ave, SE  
Washington, D.C. 20590

U.S. Department of  
Transportation

**Pipeline and  
Hazardous Materials  
Safety Administration**

**CERTIFICATE NUMBER:** USA/9036/B(U)-96

**ORIGINAL REGISTRANT(S) :**

QSA Global, Inc.  
40 North Avenue  
Burlington, MA, 01803  
USA

MDS Nordion  
447 March Road  
Ottawa, Ontario, K2K 1X8  
CANADA

Source Production and Equipment Company, Inc.  
113 Teal Street  
St. Rose, LA, 70087  
USA

Industrial Nuclear Company, Inc.  
14320 Wicks Blvd.  
San Leandro, CA, 94577  
USA

Global X-Ray & Testing Corporation  
P. O. Box 1536  
Morgan City, LA, 70381  
USA

Century Inspection, Inc.  
P.O. Box 59126  
Dallas, TX, 75229-1126  
USA

MISTRAS Holdings Group, CONAM Inspection & Engineering Services, Inc  
899 Carol Court  
Carol Stream, IL, 60188  
USA

Western Industrial X-Ray

1707 Enterprise Drive  
Unit J  
P.O. Box 238  
Fairfield, CA, 94533  
USA

High Country Fabrication (HICO)  
1000 West 1st Street  
Casper, WY, 82604  
USA

Best Medical Belgium SA  
Zoning Industriel  
Fleurus, Belgium, B-6220  
Belgium

POLATOM  
National Centre for Nuclear Research  
Radioisotope Centre  
Andrzej Solatn 7  
Otwock, Poland, 05-400  
Poland

Isoflex Radioactive  
108 Teal Street

St. Rose, LA, 70087  
USA

XCEL NDT  
2755 State Highway 322  
Longview, TX, 75603  
USA

Metalogic Inspection Services  
6529 Cunningham Rd  
Suite 2001  
Houston, TX, 77041  
United States