



**MODEL SPEC-300 RADIOGRAPHY EXPOSURE DEVICE
AND
ASSOCIATED EQUIPMENT**

OPERATING MANUAL

**Revision (6)
August 26, 2009**

**Source Production & Equipment Co., Inc.
113 Teal Street
St. Rose, Louisiana 70087 USA
Phone 504-464-9471 Fax 504-467-7685
E-MAIL: SPEC@SPEC150.com**

NOTE

The SPEC-300 Radiography System Operating Instructions within were developed to maintain compliance with US Federal and State Regulations.

For use of the SPEC-300 Radiography System within the jurisdiction of Canada, all references to US and State regulations within these instructions are non-binding.

All applicable Canadian Federal regulations pertaining to possession, use, transportation, etc. of nuclear substances in Canada are binding upon the user.

Users of the SPEC-300 Radiography System outside of the US or Canada should consult with their regulatory authorities to verify user compliance.

TABLE OF CONTENTS

1.0	GENERAL INFORMATION	-4-
1.1	Description	-4-
1.2	Safety Analysis & Regulatory Compliance	-4-
1.3	Quality Assurance	-4-
1.4	G-70 Sealed Source Description	-4-
1.5	User Qualification Requirements	-4-
1.6	Authorized Associated Equipment	-5-
1.7	Safety Precautions	-5-
1.8	Items Accompanying the Exposure Device	-5-
1.9	ASM/Lock Module, Outlet Panel Assembly and Lock Box Replacement Tools	-5-
1.10	Abbreviations	-5-
1.11	Warranty and Limitation of Liability	-6-
2.0	DESCRIPTION	-9-
2.1	SPEC-300 Exposure Device	-9-
2.1.1	Exposure Device Key	-9-
2.1.2	Device and Component Drawings	-9-
2.1.3	Labeling and Marking	-9-
2.1.4	Materials of Construction	-10-
2.2	Control Assembly	-10-
2.2.1	Control Assembly Lengths and Materials	-10-
2.2.2	Control Assembly Operation	-10-
2.2.3	Control Assembly Adaptor	-10-
2.2.4	Control Assembly Drive Cable and Connector	-11-
2.3	Guide Tubes	-11-
2.4	ANSI and Critical Component Marking	-11-
2.4.1	Drive Cable Connector	-11-
2.4.2	Control Adaptor	-11-
2.4.3	Source Assembly Connector	-11-
3.0	GENERAL CONDITIONS OF USE	-12-
3.1	Intended Use	-12-
3.2	Environmental Conditions of Use	-12-
3.3	Installation	-12-
3.4	Basic Operation	-12-
3.5	Occasions for Persons to be Near the Device	-12-
3.6	Special Equipment Use	-13-
4.0	MECHANICAL SAFETY FEATURES OF THE DEVICE	-14-
4.1	ASM/Lock Module	-14-
4.2	Exposure Device Lock	-14-

4.3	Source Assembly Lock	-14-
4.4	Automatic Securing Mechanism (ASM)	-15-
4.5	Transport Lock	-15-
4.6	No Visual "Source Position" Indicator	-16-
4.7	Source Assembly Misconnect Protection	-17-
4.8	Lock Cap	-17-
4.9	Safety Plug	-17-
4.10	Error-Free Design	-17-
4.11	Lubrication-Free Design	-17-
4.12	Tie-Down Holes	-17-
4.13	Lifting Eyes	-18-
4.14	Mobility	-18-
4.15	Protection from Unauthorized Access	-18-
5.0	RADIATION SAFETY FEATURES	-19-
5.1	External Radiation Levels	-19-
5.2	Protection from Scattered Radiation	-19-
5.3	Protection from DU Contamination	-19-
6.0	SPEC-300 SYSTEM OPERATING PROCEDURES	-20-
6.1	Safety Precautions	-20-
6.1.1	Survey Instrument	-20-
6.1.2	Personnel Training and Supervision	-21-
6.1.3	Personnel Monitoring	-21-
6.1.4	Protection from Direct Radiation	-21-
6.1.5	Protection from Scattered Radiation	-21-
6.2	SPEC-300 Radiography System Set-Up Procedures	-21-
6.3	SPEC-300 Radiography System Operation Procedures	-22-
6.4	SPEC-300 Radiography System Break-Down Procedures	-23-
6.5	Emergency Response Procedures	-23-
6.5.1	Equipment Malfunctions and Accidents	-23-
6.5.2	Fire	-24-
6.5.3	Lost or Stolen Source	-24-
7.0	SPEC-300 INSPECTION PROCEDURES	-25-
7.1	Daily Inspection Procedures	-25-
7.1.1	Survey Instrument	-25-
7.1.2	SPEC-300 Exposure Device	-25-
7.1.3	Source Assembly Connector	-26-
7.1.4	Control Assembly	-26-
7.1.5	Pistol Grip	-27-
7.1.6	Drive Cable and Drive Cable Connector	-27-
7.1.7	Control Assembly Adaptor	-28-
7.1.8	Guide Tube	-28-
7.2	Quarterly Inspection Procedures	-28-

7.2.1	Survey Instrument	-28-
7.2.2	SPEC-300 Exposure Device	-28-
7.2.3	G-70 Source Assembly Connector	-29-
7.2.4	Control Assembly	-29-
7.2.5	Guide Tube	-29-
7.2.6	SPEC-300 System Operational Check	-29-
8.0	SPEC-300 MAINTENANCE AND REPAIR PROCEDURES	-31-
8.1	General	-31-
8.2	Recommended Replacement Components	-31-
8.3	Modifying, Repairing or Tampering with the Device	-31-
8.4	SPEC-300 Exposure Device	-32-
8.5	ASM/Lock Module	-32-
8.5.1	Lock Box Removal	-32-
8.5.2	ASM/Lock Module Replacement Procedure	-33-
8.6	Outlet Panel Assembly	-35-
8.6.1	Outlet Panel Assembly Replacement Procedures	-35-
8.7	Lock Cap, Safety Plug, Key and Control Adaptor	-36-
8.8	Radiation Profile Survey Procedures	-36-
8.9	G-70 Source Assembly	-36-
8.10	Control Assembly Maintenance and Repair	-36-
8.10.1	Control Assembly Disassembly	-37-
8.10.2	Control Assembly Internal Component Inspection	-37-
8.10.3	Control Assembly Cleaning Procedures	-37-
8.10.4	Control Re-assembly Procedure	-39-
8.11	Guide Tube	-40-
9.0	TRANSPORTATION PREPARATIONS	-41-
9.1	Procedures for Preparing and Loading the Package	-41-
9.1.1	General Package Inspection	-41-
9.1.2	Packaging	-41-
9.1.3	Outer Package Surface Contamination	-41-
9.1.4	Transportation Requirements	-42-
9.1.5	Type B Quantity Consignee Notification	-42-
9.2	Procedures for Receipt and Unloading the Package	-42-
9.2.1	Receiving the SPEC-300	-42-
9.2.2	Unloading the SPEC-300	-43-
9.3	Preparation of an Empty Package for Transport	-43-
	APPENDIX	-45-

1.0 GENERAL INFORMATION

1.1 Description

The SPEC-300 is a mobile ANSI N432-1980 Type 1 (Category II for ANSI N43.9), depleted uranium shielded Cobalt 60 exposure device used for industrial gamma radiography nondestructive testing applications. The SPEC-300 system consists of the SPEC-300 exposure device (camera), a model G-70 source assembly and associated equipment. The associated equipment includes a manual remote control assembly, guide tube and collimator. The G-70 is a Cobalt 60 radioactive sealed source with a maximum activity of 300 curies (11,100 GBq). The control assembly is used to move the source out of the exposure device and into the guide tube to perform radiography. The collimator provides radiation shielding at the end of the guide tube.

1.2 Safety Analysis & Regulatory Compliance

The model SPEC-300 system exposure device, model G-70 source, and associated equipment meet the requirements specified in ANSI N432-1980 "Radiological Safety for the Design and Construction of Apparatus for Gamma Radiography," and 10 CFR Part 34.20 "Performance Requirements for Radiography Equipment." The SPEC-300 System is approved by the Louisiana Radiation Protection Division. A Registry Sheet is available upon request.

1.3 Quality Assurance

The SPEC-300 System is manufactured under the control of the SPEC Quality Assurance Program. SPEC has been issued Quality Assurance Program Approval for Radioactive Material Packages, Number 0102, by the U.S. Nuclear Regulatory Commission. The Quality Assurance Program controls the design, fabrication, assembly, testing, use, maintenance and repair of radioactive material packages, exposure devices, sources and associated equipment.

1.4 G-70 Sealed Source Description

The model G-70 source meets ANSI N542 classification 77C43515. The source meets U.S. Department of Transportation 10 CFR Part 34, 49 CFR, and International Atomic Energy Agency (IAEA) requirements for Special Form Radioactive Material. It is authorized for transport under IAEA Certificate of Competent Authority for Special Form Radioactive Materials Certificate Number USA/0566/S. The G-70 source is approved by the Louisiana Radiation Protection Division. A Registry Sheet is available upon request.

1.5 User Qualification Requirements

Users are required to be specifically licensed by the Nuclear Regulatory Commission or an Agreement State to use the SPEC-300 in the United States. National regulations may apply in other countries. Radiography workers must be formally trained and qualified in the safe use of the SPEC-300 system, survey instruments, and general radiation safety. They must be specifically authorized by the licensee to use the SPEC-300. The SPEC-300 must be used in strict compliance with the licensee's Operating and Emergency Procedures, applicable safety regulations, and all operation, inspection and maintenance instructions in this manual.

1.6 Authorized Associated Equipment

The SPEC-300 is authorized for use with approved control assemblies, flexible "brass" guide tubes, rigid "J" tubes and collimators that are designed, tested, manufactured and inspected by SPEC in accordance with 10 CFR Part 34.20 regulations. Replacement sources and associated equipment manufactured by other authorized manufacturing companies may be tested and submitted for approval for use with the SPEC-300 exposure device. Licensees should consult with the applicable NRC or Agreement State licensing agency to determine if specific authority is required to use custom-made associated equipment such as extra length guide tubes.

1.7 Safety Precautions

The SPEC-300 must be used only by authorized and monitored individuals who have been formally trained in the use of this device, the proper use of survey instruments, and general radiation safety. This device must be used in strict compliance with the licensee's Operating and Emergency Procedures and all applicable government safety regulations to assure that exposure to workers and the public is maintained AS LOW AS REASONABLY ACHIEVABLE (ALARA) below established dose limits.

The SPEC-300 must be used with a calibrated and operable survey instrument at all times. THE USE OF OTHER DEVICES (SUCH AS ALARMING RATEMETERS, BEEPERS, AND AREA ALARMS) INSTEAD OF A SURVEY INSTRUMENT IS EXTREMELY DANGEROUS AND NEGLIGENT. Trainees, helpers and assistants must operate the device only under the direct visual surveillance of a qualified radiographer. It is recommended that licensees provide workers with NRC publication "Working Safely with Gamma Radiography" NUREG/BR-0024 or similar radiography safety guide.

1.8 Items Accompanying the Exposure Device

1. SPEC-300 Operating Manual
2. Model 1 Leak Test Kit and instructions
3. Quality Assurance Final Inspection Certificate. The certificate includes a radiation profile report.
4. SPEC-300 Annual Maintenance Program information flier
5. 6 ea. tamper seals for transport

1.9 ASM/Lock Module, Outlet Panel Assembly and Lock Box Replacement Tools

A set of special tools to remove/replace the lock box, ASM/Lock Module and outlet panel assembly are loaned as needed and are available for purchase. Contact SPEC Sales Department at 504-464-9471 for information.

1.10 Abbreviations

ANSI American National Standards Institute
ASM Automatic Securing Mechanism
ISO International Organization for Standardization

IAEA International Atomic Energy Agency
DU Depleted Uranium
SPEC Source Production & Equipment Co., Inc.
TMJ SPEC Thermal Metal Joining Special Process

1.11 Warranty and Limitation of Liability

Source Production & Equipment Co., Inc. (SPEC) warrants that on the date the exposure device or source changer is sold, it will meet SPEC's standard specifications for exposure devices and source changers will be free of defects in material and manufacture. THIS WARRANTY APPLIES ONLY AGAINST DEFECTS AND NONCONFORMITIES THAT ARE DISCOVERED WITHIN ONE (1) YEAR FROM THE DATE OF FIRST SALE BY SPEC OR AN AUTHORIZED SPEC DEALER. ALL SPEC MANUFACTURED SOURCE ASSEMBLIES, ASSOCIATED EQUIPMENT AND REPLACEMENT PARTS OF RADIOGRAPHY SYSTEMS (E.G. CONTROL ASSEMBLIES, GUIDE TUBES, ASM/LOCK MODULE UNITS, CONTROL ADAPTORS, ETC.) AND ALL OTHER SPEC MANUFACTURED PRODUCTS ARE WARRANTED TO BE FREE OF DEFECTS AND NONCONFORMITIES FOR A PERIOD OF THIRTY (30) DAYS FROM THE DATE OF FIRST SALE. If the Buyer discovers the defects or nonconformities, Buyer must notify SPEC in writing, certified, and post marked within thirty (30) days after the date of discovery and in no event later than thirteen (13) months after the date of first sale for exposure devices and sixty (60) days for associated equipment to Attn: Sales Manager, 113 Teal Street, St. Rose, LA 70087.

SECTION OF LAW AND FORUM

The Buyer and SPEC hereby specifically agree that this sale shall be deemed consummated in the State of Louisiana. SPEC and Buyer hereby agree that the laws for the State of Louisiana will apply to this agreement in its interpretation and enforceability. In addition, SPEC and buyer agree that any controversy and/or litigation concerning the purchase of SPEC's product by Buyer shall be held and filed in a court of competent jurisdiction within the Parish of Jefferson, State of Louisiana.

DISCLAIMER OF WARRANTIES

Any Warranties of the product herein sold are only those provided by SPEC. SPEC hereby expressly disclaims all warranties, except those warranties that have been provided in the above section entitled "[SPEC Product Limited Warranty]". SPEC hereby expressly disclaims all or any other express or implied warranties, including any implied warranty of merchantability or fitness for a particular purpose. SPEC neither assumes nor authorizes any other person to assume for it any liability in connection with the sale of its product.

It is specifically understood between the buyer and SPEC, that this sale is made without any warranty not included within SPEC's express warranties (as provided above) except as to title. The buyer herein specifically waives the implied warranties provided for by Louisiana law and any other state law (should a court of competent jurisdiction not honor the parties selection of Louisiana law to govern its relations), including all warranties against vices or defects for any particular purpose. This express waiver shall be considered a material and integral part of this sale. There are no exceptions to the foregoing provision

except as maybe expressed in writing by SPEC.

BUYER'S REMEDIES

If the exposure device fails to conform to the warranties in paragraph 1 and such nonconformity is not due to misuse or improper maintenance, Buyer shall notify SPEC as provided in paragraph 1, and within a reasonable time, SPEC shall provide at its option, one of the following:

- 1) repair or replacement of any nonconforming or defective parts, or
- 2) full refund of the purchase price or reduced refund based on age and use of equipment.

THIS REMEDY SHALL BE THE EXCLUSIVE AND SOLE REMEDY OF BUYER FOR ANY BREACH OF WARRANTY.

Should any provision, aspect or term of this waiver of warranties be deemed unenforceable for any reasons, it is specifically agreed by SPEC and/or its product distributors and the buyer that the aspect, provision and/or term found unenforceable shall be severed from the agreement as a whole so the most limited extent necessary. All other aspects, terms, and provisions shall maintain their full force and effect.

EXCLUSION OF CONSEQUENTIAL AND INCIDENTAL DAMAGES

IN NO EVENT SHALL SPEC BE LIABLE FOR ANY INCIDENTAL, SPECIAL, INDIRECT, OR CONSEQUENTIAL DAMAGES, WHETHER RESULTING FROM NONDELIVERY OR FROM THE USE, MISUSE, OR INABILITY TO USE THE PRODUCT OR FROM DEFECTS IN THE PRODUCT OR FROM SPEC'S OWN NEGLIGENCE OR OTHER TORT. This exclusion applies regardless of whether such damages are sought for breach of warranty, breach of contract, negligence, or strict liability in tort or under any other legal theory.

EXCLUSION OF LIABILITIES

The purchaser of SPEC's product, by purchasing the product, attests to SPEC, its distributors and all other third parties that it is a knowledgeable, experienced and a sophisticated user of said product. Buyer hereby warrants that it fully understands the dangerous nature of the radioactive material together with the safety and regulatory requirements attendant to its use. Buyer hereby warrants that it will use and maintain the purchased product in a manner which does not violate Nuclear Regulatory Commission or equivalent Agreement State license conditions and regulations imposed upon the licensee or worker regarding the safe use of the equipment.

The foregoing warranties and liabilities of SPEC and remedies of Buyer are exclusive, and Buyer waives and releases all other warranties, obligations, and liabilities of SPEC and all other remedies, claims, and rights of Buyer relating in any way to the equipment covered by this agreement, whether arising from contract, warranty, or tort or from negligence, tort, or other fault of SPEC, including claims for loss of or damage to the equipment. SPEC assumes no liability or responsibility for any damages or injuries, regardless of cause, resulting from the use of SPEC manufactured equipment, or resulting from the use of any radioactive material or associated equipment in a manner that violates Nuclear Regulatory Commission or equivalent Agreement State license conditions and regulations imposed on the licensee or worker regarding the safe use of the equipment.

This warranty shall not apply to products or parts that have been subjected to misuse, improper installation, unauthorized repairs or modifications, neglect or accident conditions. The warranty is void if equipment is not operated and maintained in accordance with instructions provided in SPEC operating manuals. The customer is responsible for returning products to SPEC, freight prepaid, and for preparing the product for shipment in accordance with applicable transport laws and regulations.

2.0 DESCRIPTION

2.1 SPEC-300 Exposure Device

The device (camera) consists of a depleted uranium shield inside a welded stainless steel housing measuring approximately 66 cm (26 inches) long x 35.6 cm (14 inches) wide x 38.1 cm (15 inches) high. The DU shield includes a curved S-tube that the source travels through. The securing and locking mechanisms are installed at one end of the device and an outlet port (outlet nipple) is installed at the other end. The device weighs a maximum of 354 kg (780 pounds).

2.1.1 Exposure Device Key

The device key is attached to the control assembly by a short stainless steel chain to prevent loss of the key. When the controls are not in use, the key is installed in the open end of the adaptor to serve as a dust cap to protect against ingress of foreign material into the control assembly. As an option, the key may be removed from the control assembly and replaced with a conventional dust cover.

2.1.2 Device and Component Drawings

Drawings of the SPEC-300 Exposure Device, ASM/Lock Module, Safety Plug, Outlet Panel Assembly, Lock Cap, Lock Box, Control Assembly Adaptor, Drive Cable Connector, G-70 Source Assembly and Special Tools are in Appendix #1 to this manual.

2.1.3 Labeling and Marking

1. The exposure device nameplate is marked with SPEC's name, address, device model, serial number, curie capacity and radionuclide, mass of depleted uranium shielding, and device weight.
2. One caution label stating "Caution - Radioactive Material - Do Not Handle - Notify Civil Authorities if Found."
3. The warning labels state:

WARNING - DANGER

⚠ Radiation may cause radiation burns, sickness, cancer, genetic defects, and death. This device may be used only by authorized and monitored individuals who have been formally trained in the use of this device, the proper use of survey instruments, and radiation safety. This device must be used in strict compliance with operating and emergency procedures and applicable regulations. It must be used with a calibrated survey instrument at all times. Trainees, helpers and assistants must work under the direct surveillance of a radiographer ⚠

4. The source identification tag lists the isotope, source model, serial number, activity, and date of manufacture. A tag is provided with each source.
5. Licensees must apply their company name, address and telephone number to the exterior of the exposure device to meet 10 CFR Part 34.20 (b) (v). The labeling may be painted directly on the device or a printed label may be attached by adhesives. Drilling, riveting or welding is prohibited.

2.1.4 Materials of Construction

The principal materials used in the SPEC-300 are a depleted uranium shield and a stainless steel housing and structure. Stainless steel fittings, bronze bushings, copper pads, polyurethane foam fill and rubber are non-structural materials of construction.

2.2 Control Assembly

The control assembly, commonly called a crank-out, is a manually operated mechanical apparatus used to move the source assembly from the exposure device to the exposed working position at the end of the guide tube and back into the exposure device. It consists of a pistol grip assembly, two conduits (sheaths) typically 25 to 50 feet long, a flexible metal drive cable with a connector to attach to the source assembly, a drive cable stop, and an adaptor to attach the control assembly to the exposure device. The pistol grip consists of an aluminum housing, drive gear, wear ring, two bearings, cover plate, and crank handle.

2.2.1 Control Assembly Lengths and Materials

Control assemblies are available in a variety of conduit materials and lengths. To limit worker exposure to radiation, it is highly recommended that the user keep dosage as low as reasonably achievable (ALARA) by using the longest control assembly practical for the radiographic procedure.

	Max. Length
Controls with Yellow conduit	35 ft.
Controls with Blue conduit	50 ft.
Controls with two types of conduit	See Note 1

Note 1: The length of a control assembly made with two types of conduits (i.e., Yellow and Blue) is limited by the maximum length specified for the type of conduit installed on the drive (upper) side of the control assembly pistol grip.

Note 2: Custom designed, or extra length control assemblies may require government authorization. Consult with SPEC or your licensing authority to verify.

2.2.2 Control Assembly Operation

The control assembly is typically operated by hand, yet may be operated mechanically. The pistol grip cover plate is permanently marked with the words "expose" and "retract" and with arrows to indicate the directions of cranking motion to expose or retract the source assembly. The typical amount of torque required to operate the system freely with a manual control assembly is approximately 2 foot pounds. If an automatic mechanical apparatus is used to operate the control assembly, the maximum amount of torque allowed to be applied to the drive gear is 4 foot pounds.

2.2.3 Control Assembly Adaptor

The adaptor is used to attach the control assembly to the exposure device. After the device is

unlocked, the spring-loaded operating lever on the adaptor is used to unlock the source assembly. The adaptor may be used on any control assembly authorized for use with the SPEC-300.

2.2.4 Control Assembly Drive Cable and Connector

The drive cable is a flexible wire steel cable with a connector at one end (to attach to the source assembly) and a spiral "stop" spring at the other end (to prohibit accidental loss). The cable meshes with the gear inside the pistol grip and is moved as the control handle is rotated. The drive cable connector is the SPEC Fail-Safe (Model 3) connector.

2.3 Guide Tubes

Guide tubes are hollow flexible or rigid tubes with an end piece (exposure head) attached to the working (exposure) end. SPEC "Blue" material designates steel flexible conduit jacketed with Blue PVC, 1/2" inside diameter flexible guide tube. SPEC "Rigid" material designates Type 304 or 316 stainless steel, 1/2" inside diameter, non-flexible guide tube. This material is used for "J" tubes and other specialized applications. The maximum length, with extension(s), is 21 feet. Longer and custom designed guide tubes may require government authorization. Consult with SPEC or your licensing authority to verify.

2.4 ANSI and Critical Component Markings

An earlier revision to 10 CFR 34.20 required the marking of associated equipment to indicate compliance with the ANSI N432-1980 testing and performance requirements. The marking requirement has since been deleted from the May 1997 revision of 10 CFR Part 34. SPEC will continue to mark or label those components that are considered critical to the safe operation of the system. The components critical to safe operation are the drive cable connector, the control adaptor, and the source assembly connector.

2.4.1 Drive Cable Connector

The drive cable connector is permanently marked with a three (3) character alphanumeric code (one letter and two numerals). The marking is stamped inside the crimped region on the body of the swaged-on connector. The characters are 1/32 inch in height.

2.4.2 Control Adaptor

The control adaptor is marked on the with a seven (7) or eight (8) digit numerical code. The digits are stamped on the flat plate portion of the control adaptor and are 1/32" in height.

2.4.3 Source Assembly Connector

The source assembly connector is permanently marked with a six digit alphanumeric code (two letters and four numbers). The marking is engraved on the body of the source connector.

3.0 GENERAL CONDITIONS OF USE

3.1 Intended Use

The SPEC-300 exposure device is intended for industrial gamma radiography operations at temporary job site and permanent facilities in all industries and locations. Typical industries and locations are associated with oilfield, petrochemical, marine, construction, manufacturing, and aerospace activities. It is expected that the equipment will be used at offshore structures, metal fabrication yards, foundries, chemical plants, refineries, shipyards, building sites, laboratories, and maintenance facilities. Use of the SPEC-300 is not limited to these areas.

3.2 Environmental Conditions of Use

The SPEC-300 exposure device is designed to perform industrial radiography at field sites and permanent facilities with a broad range of environmental conditions. It will operate properly within a temperature range of -40 degrees F to +180 degrees F and in all levels of relative humidity and moisture. The device is resistant to corrosion from typical industrial and environmental atmospheres. For use underwater, the device must be installed in a protective enclosure or other precautions taken to prohibit damage to internal components due to slow corrosion. Licensees should consult with the applicable government licensing agency to determine if specific authority is required to use the SPEC-300 exposure device underwater.

3.3 Installation

There are no installation requirements.

3.4 Basic Operation

In typical use, a manual remote control assembly and guide tube are attached to the device during set up of the SPEC-300 System. The exposure device is unlocked with a key, then the source assembly is unlocked with the control adaptor operating lever. Before each radiographic exposure, the source assembly is unsecured from the automatic securing mechanism (ASM) by depressing the release plunger on the top of the lock box by hand, foot or remote unsecuring mechanism (RUM). The control assembly is used to move the source assembly out of the shielded position to the final working position at the end of the guide tube. When the source assembly is retracted back into the fully shielded position inside the device, it is automatically secured by the ASM. Finally, a safety check must be performed with a survey instrument after each exposure. See Section 6.2 through 6.4 for detailed system set-up, operating and break-down instructions.

3.5 Occasions for Persons to be Near the Device

Only specifically trained, authorized, and monitored individuals are allowed to be within the restricted area when the device when it is in use. It is expected that unmonitored persons, such as shipping, receiving and transport personnel will be near the device only after it has been properly prepared for transport.

3.6 Special Equipment Use

If the SPEC-300 must be used in working positions that are difficult or dangerous for the worker to reach (for example, when suspended off the ground), it is recommended that the licensee use a remote unsecuring mechanism (RUM).

4.0 MECHANICAL SAFETY FEATURES OF THE DEVICE

4.1 ASM/Lock Module

The ASM/Lock Module is installed inside the lock box which is bolted to the lock end plate of the device. The ASM/Lock Module contains the exposure device lock, source assembly lock, and the automatic securing mechanism (ASM). It is easily replaced by authorized users without special training. The safety features are described below.

1. The module is a self contained unit that requires NO disassembly for cleaning, maintenance, or lubrication by the user.
2. Special tools (provided by SPEC) are required to remove the module. This protects against unauthorized removal.

4.2 Exposure Device Lock

The device lock is located at the bottom of the lock box. It prohibits unlocking the source assembly lock when engaged. It is operated by a durable, circular, stainless steel key. The safety features of the device lock are described below.

1. The key cannot be intentionally removed nor inadvertently fall out when the device is unlocked.
2. The key serves as a dust cover for the device lock and limits ingress of foreign material when the device is in use. The key may also be used as a dust cover for the control assembly when it is not in use.
3. The key must be removed to disconnect the control adaptor from the exposure device. Therefore, the key cannot be inadvertently left in the device when breaking down the system.
4. The lock cannot be unlocked with a readily available substitute for the key.
5. The lock cannot be removed from the ASM/Lock Module.
6. The key's thumb grooves point to the "Lock" or "Unlock" positions that are permanently marked (stamped) on both sides of the lock box to indicate the status of the device lock.

4.3 Source Assembly Lock

The source assembly lock is located at the center of the lock box. It prohibits movement of the source assembly in both directions when engaged. It is manually operated by use of the operating lever on the control assembly adaptor. The lever must be inserted and then rotated toward the "Unlock" position to disengage the source assembly lock. The numerous safety features of the source assembly lock are described below.

1. The control assembly adaptor must be properly attached to the exposure device to operate the source assembly lock. The control adaptor cannot be attached to the device unless the drive cable connector and the source assembly connector are properly connected.
2. The source assembly lock cannot be disengaged unless the exposure device is unlocked.
3. The source assembly lock cannot be operated with a readily available substitute for the

- control assembly adaptor operating lever.
4. When the source assembly lock is engaged, the release plunger cannot be engaged (latched down). Therefore, the source assembly cannot be inadvertently unsecured.
 5. The source assembly lock can be conveniently engaged to provide an added measure of security during temporary interruptions in radiography operations. Therefore, the worker does not have to use the control assembly to resecure the source assembly.
 6. The exposure device cannot be locked when the source assembly lock is disengaged.
 7. In accordance with ANSI N432 Section 5.1.2.4, the source assembly lock **ABSOLUTELY, POSITIVELY** cannot be engaged unless the source assembly has been retracted to the fully secured position. Therefore, the user cannot inadvertently lock the source out.

4.4 Automatic Securing Mechanism (ASM)

The ASM automatically secures the source assembly when it is fully retracted into the device. It prevents movement of the source assembly toward the outlet end. The source assembly must be unsecured from the ASM by depressing the release plunger located at the top of the lock box before each radiographic exposure. The release plunger latches in the engaged (down) position when pushed down. When the source assembly is cranked forward, the release plunger automatically unlatches and pops back up to its original position. The safety features of the ASM are described below.

1. **THE ASM CANNOT TRIP PREMATURELY AND LOCK THE SOURCE ASSEMBLY OUT!** It has no moving parts and is very reliable.
2. **THE ASM CANNOT BE MECHANICALLY DEFEATED!** Vice grips, clamps, pins and duct tape cannot be used to defeat the ASM. If the release plunger is held down, the source assembly cannot be cranked out of the device.
3. The ASM release plunger is **ABSOLUTELY NOT** a source assembly position indicator. It springs up as soon as the source assembly is cranked forward, not after it is cranked back into the device. Therefore, it cannot be misconstrued as being a source position indicator, secured position indicator, nor any other type of potentially hazardous mechanical/visual indicator that is subject to **FALSE-POSITIVE** indications of safety. It cannot "invite", nor influence, the worker to refrain from using the survey instrument.
4. No "extra" cranking force is needed to secure the source assembly when it is cranked back into the device. The securing mechanism uses no springs and is completely automatic.
5. The ASM provides a mechanical means for the user to verify that the source assembly is in the secured position. This is accomplished by gently attempting to crank the source assembly forward after it has been retracted into the device.
6. The release plunger is very durable and may be operated by hand, foot or remote unsecuring mechanism (RUM).
7. The ASM also prohibits the source assembly from being pulled out of the lock end of the device even when both locks are open.

4.5 Transport Lock

The device is fitted with an independent locking system called the Transport Lock. It provides the primary locking of the source assembly during transport and storage and during ASM/Lock Module replacement. The safety features of the Transport Lock are described below.

1. The transport lock must be engaged before the lock box can be removed from device to perform the module replacement procedure.
2. When the transport lock is engaged, the pad lock knob will protrude through the side of the device indicating that the transport lock is in the engaged position.
3. Once the transport lock is engaged, a padlock is installed to prevent inadvertent disengaging of the locking system until the ASM/Lock Module replacement procedure is completed.

4.6 No Visual "Source Position" Indicator

The SPEC-300 system is free of any mechanical/visual device that could be misconstrued as being a "source position" indicator of any type. Typical source position indicators are potential safety hazards. This opinion is based on (a) the current state of technology, (b) current industry and government expert opinion regarding indicators, and (c) current scientific safety research. The potential hazards associated with mechanical source position indicators have been debated for many years in the radiography industry. Each point is explained in more detail below to assist licensees in providing safety training to workers.

1. The current state of technology does not offer an indicator design that provides a greater degree of safety to the worker than the survey instrument. Existing mechanical indicators are not true "redundant" safety devices since they do not provide an equal level of reliability as the survey instrument. The superior reliability of the survey instrument is based on two facts. First, it responds to radiation, not the mechanical presence of a component of the source assembly. Second, the operability of a survey instrument can be easily, conveniently, and reliably determined by the worker at a glance each time the instrument is used. No additional separate inspection is necessary to verify that it is responding to radiation. Mechanical indicators require a separate, independent inspection of some sort to verify proper operation. Malfunctions are not readily apparent to the worker.
2. Industry and government opposition to visual indicators is reflected in various public records. The public comments submitted to the NRC in response to a Proposed Rule in 1989 to require an indicator were overwhelmingly in opposition to the indicator. The proposed rule was later withdrawn by the NRC based on safety concerns. The Atomic Energy Control Board of Canada also reviewed and rejected a proposed rule to require a visual indicator on radiography exposure devices. This opinion is also reflected in the current revisions of ANSI N43.9-1991 and ISO 3999 standards.
3. Mechanical/visual indicators are subject to FALSE-POSITIVE indications of safety. Automatic securing mechanism malfunctions due to wear, foreign matter, corrosion or defects often cause them to trip prematurely with the source out, causing the mechanical/visual indicator to falsely indicate a safe condition. They can also provide false-positive indications even when they are functioning properly, such as when a source capsule is detached from the source assembly. Documented incidents have occurred in which mechanical/visual indicators gave false-positive indications of safety that resulted in human fatalities. The false-positive indications influenced the workers to refrain from using their survey instruments, which could have prevented the fatalities.

4. Finally, mechanical/visual source position indicators conflict with basic safety theory described in the scientific human factor safety research. Research shows that it is counterproductive to provide "safety" features that reduce the worker's perception of risk to a level that produces an offsetting reduction in human safety behavior.

4.7 Source Assembly Misconnect Protection

The control assembly adaptor cannot be attached to the exposure device if the drive cable connector is not attached to the source assembly connector. This prohibits operation of the device when a "misconnect" between the drive cable and source assembly exists. The licensee should ensure that the drive cable connector used to operate the device is compatible for use with the system, does not compromise the safety features of the system and is authorized for use. The SPEC Fail Safe drive cable (#3) connector is used to operate the SPEC-300 exposure device and G-70 source model.

4.8 Lock Cap

The lock cap is a titanium assembly that attaches to the control assembly attachment boss located at the top center of the lock box. It is used to protect against ingress of foreign material when the device is not in use and to protect the source assembly connector from accidental impact. The lock cap must be installed during transport or storage.

4.9 Safety Plug

The safety plug is a stainless steel assembly that attaches to the outlet nipple. It is used to protect against ingress of foreign material in the outlet nipple when the device is not in use, and to shield scattered radiation streaming from the outlet nipple. It must be installed during transport as a redundant means to prevent loss of the source assembly in an accident.

4.10 Error-Free Design

The SPEC-300 design uses a 'lock step' set-up and break-down process that prohibits workers from doing steps that are inadvertently out of the proper sequence or from omitting steps.

4.11 Lubrication-Free Design

Although the SPEC-300 Exposure Device is designed to operate reliably without lubrication, users may use lubrication that is suitable for the operating environment. If lubrication is used, users should consider the need to perform maintenance to remove and/or replace the lubrication if significant changes in environment are encountered.

4.12 Tie-Down Holes

The SPEC-300 exposure device has four convenient holes located at the top corners of each housing protective flange. The tie-down holes provide a sturdy means to attach security harnesses, and permanent installation mounts. The tie down holes may be used for lifting the device and will support 25 times the

weight of the device.

4.13 Lifting Eyes

Two (2) pivoting lifting eyes are located to the top of the device for attaching lifting cables, harnesses or other lifting attachments. They will support 25 times the weight of the device.

4.14 Mobility

As required by ANSI N432-1980, Section 5.3, the device incorporates a means for mobility and is fitted with an immobilization device. The means for mobility is a welded steel cart fitted with a disc brake system. The steel cart is designed for easy maneuverability by one person once the disc brake system is disengaged. The brake system is continuously engaged unless purposely and manually released by the user at the time the device is being moved. To disengage the brake, simply retract the release handle attached to the top of the handle of the cart. The brakes are automatically re-engaged anytime the user releases the brake release handle.

4.15 Protection from Unauthorized Access

The SPEC-300 exposure device is designed to prevent access to the radioactive source by unauthorized personnel, such as the public. The design features that contribute to the prevention of unauthorized access are noted below.

1. The SPEC-300 is equipped with a keyed device lock. It cannot be unlocked by a readily available substitute for the key.
2. The device lock, source lock and securing mechanism cannot be removed from the ASM/Lock Module.
3. The ASM/Lock Module, Outlet Panel Assembly, Lock Box and Transport Lock are able to be removed from the device. They are removed only with the use of special tools that are not commonly available. It is recommended that access to the special tools be controlled by the Radiation Safety Officer or authorized designee.
4. The source assembly lock cannot be unlocked without the use of the control assembly operating lever, which can be used only when the control adaptor is attached to the device. There is no readily available substitute for the operating lever.
5. The source assembly cannot be removed without a key and control assembly.
6. Caution and warning labels are permanently attached to the device which clearly explain the hazards of radiation and provide instructions to notify civil authorities if found.
7. The lock box is structurally protected against intentional unauthorized removal by destructive force (i.e. sledge hammer).

5.0 RADIATION SAFETY FEATURES

5.1 External Radiation Levels

In accordance with ANSI N432-1980, external radiation levels of the device will not exceed 2 mSv (200 mR/hr) at the surface and 50 μ Sv (5 mR/hr) at one meter from the surface when loaded to maximum activity capacity of 11.1 TBq (300 curies).

5.2 Protection from Scattered Radiation

The safety plug shields the scattered radiation at the outlet nipple and must be installed at all times when a guide tube is not attached and when the device is stored or transported. The lock cap shields the scattered radiation at the lock end of the device and also must be attached when the device is stored or transported.

5.3 Protection from DU Contamination

The depleted uranium shield is completely enclosed in a stainless steel housing. The S-tube protects the source assembly from depleted uranium contamination inside the shield.

6.0 SPEC-300 SYSTEM OPERATING PROCEDURES

6.1 Safety Precautions

6.1.1 Survey Instrument

Safe operation begins with inspecting the survey instrument to verify that it is operating properly. The inspection must be done in accordance with safety regulations 10 CFR 34.31 and employer operating procedures before the SPEC-300 is handled or prepared for transport. It is recommended that each worker inspect the exact survey instrument to be used during that work shift.

The survey instrument **MUST** be used after each exposure regardless of other safety equipment being used such as a control assembly odometer, area alarm, radiation beeper (chirper), or alarming ratemeter. All of the above items are less reliable than a survey instrument and are subject to FALSE-POSITIVE indications of safety.

Workers should note the radiation levels during the first exposure of each new set up. The survey instrument's response to radiation should be approximately the same for each subsequent exposure. Observing the instrument's response during an exposure is a very reliable indication of the operability of the instrument. Unusual readings should be treated as a potentially hazardous condition and should be resolved before proceeding. It could be caused by a defective survey instrument, exposure device, or source assembly.

Regulations require that the survey instrument's response to radiation be verified daily. Licensee's Operating Manuals typically require that radiation levels of the device be measured before removing the exposure device from storage in maintaining Utilization Logs. A quick, simple procedure called a "reference reading" will provide valuable safety information. To obtain a reference reading, the survey instrument should be placed at the surface of one side of the exposure device. The reference reading should be recorded. Obtaining the reference reading also verifies meter response to radiation.

Periodically during the work shift, and whenever damage to the survey instrument is suspected, a radiation reading should be made at the same spot and compared with the reference reading to determine if the survey instrument's response to radiation has changed. A **SIGNIFICANT** change in radiation reading should be treated as a potentially hazardous condition and should be resolved before proceeding. It could be caused by a defective survey instrument, exposure device or source assembly.

The same spot on the surface of the device should be surveyed to obtain the reference reading every day. This is so the reference reading will remain approximately the same from day to day if the same source and survey instrument are used. The decay rate of Cobalt 60 is approximately 1% per month.

6.1.2 Personnel Training and Supervision

All workers must be specifically trained, qualified and authorized to use the SPEC-300 by the licensee. Helpers, trainees and assistants must operate the SPEC-300 only under the direct visual surveillance of a qualified radiographer.

6.1.3 Personnel Monitoring

Personnel radiation monitoring devices must be used at all times in accordance with regulations and employer Operating and Emergency Procedures.

6.1.4 Protection from Direct Radiation

Protection from direct radiation is provided by the DU shield when the source is properly secured in the device. When the source is moved out of the device to perform radiography, the radiation beam is fully unshielded in all directions when moving through the guide tube to the working position. To limit human exposure to radiation, collimators should be used when possible to reduce direct radiation in unwanted areas when the source is exposed. Collimators are available in a variety of sizes, shapes and shielding capabilities to meet safety requirements. Additionally, to reduce direct radiation exposure, it is recommended that the longest control assembly and shortest guide tube practical for the radiographic procedure be used.

6.1.5 Protection from Scattered Radiation

Individuals should refrain from placing fingers in front of the outlet nipple opening when the safety plug is removed. No special precautions are required to protect the fingers when installing a guide tube or performing a wipe test other than to complete the procedure quickly, which is normally a few seconds. The dose to the fingers will be approximately 1 mR/second with a 100 curie source.

6.2 SPEC-300 Radiography System Set-Up Procedures

WARNING WARNING WARNING

A calibrated and properly operating survey instrument must be used at all times when handling or using the SPEC-300 Exposure Device. Failure to comply with this requirement is a violation of safety regulations and may result in harmful radiation overexposure, injury and death in the event of human error, equipment malfunction, or accident.

1. Inspect the survey instrument to verify proper operation.
2. Survey the exposure device to verify the source is properly shielded. It is recommended that the worker make and record a reference radiation reading as described in Section 6.1.1.
3. Disconnect the safety plug from the outlet end of the device and store it in the storage outlet nipple attached to the outlet end plate of the device.
4. Attach the guide tube to the outlet nipple and verify that it is securely fastened by tugging lightly after the connection is made.
5. Remove the spring loaded lock cap by rotating the cap counter-clockwise 45 degrees. It may be stored by attaching it to the boss fitting located on the outlet end flange.

6. Remove the dust cover from the control assembly and crank out a few inches of drive cable.
7. Attach the drive cable connector to the source assembly connector by retracting the piston in the source assembly connector and inserting the drive cable connector at an approximate 90 degree angle. Swivel the drive cable into alignment.
8. Crank the controls to retract the drive cable until the control adaptor is drawn flush with the device.
9. Attach the control adaptor to the control attachment boss at a 45 degree angle and rotate clockwise until rotation stops. The control adaptor should be in the vertical position.
10. Extend the control assembly and guide tube as straight as possible and avoid sharp bends. Avoid dragging the conduits over objects that might catch, cut or melt them.
11. If applicable, attach a collimator to the guide tube.

6.3 SPEC-300 Radiography System Operation Procedures

1. Disengage the transport lock by removing the padlock from the transport lock's knob and then sliding the transport lock fully to the left. Install the retaining pin to keep the transport locking the disengaged (open) position.
2. To unlock the device, insert the key into the device lock. Push the key in and rotate clockwise approximately 45 degrees until the rotation stops. The device key will point towards the "UNLOCK" position.
3. To unlock the source assembly, push the control adaptor operating lever into the device and rotate counter-clockwise approximately 45 degrees until rotation stops. The operating lever handle will point towards the "UNLOCK" position.
4. To unsecure the source assembly, push the release plunger until it latches in the unsecured (down) position. The source assembly is now able to be cranked out of the device.
5. Rotate the crank handle on the control assembly pistol in the 'expose' direction to expose the source. The release plunger will immediately spring up when the source assembly is cranked forward.
6. When the desired exposure time has elapsed, rotate the crank handle in the 'retract' direction to retract the source assembly.
7. Test to verify that the source assembly is secured by relaxing backward (retracted) cranking force and then applying slight forward (expose) cranking motion. The source assembly should be unable to move forward.

CAUTION!!

If the source can be cranked forward, attempt to resecure it by cranking it back and test it again. If it cannot be secured, the equipment has malfunctioned. Apply slight retracting force to the control assembly crank handle while surveying the device to verify that no radiation hazard exists and lock the source and device. Immediately remove the device from use.

8. Approach the exposure device with a survey instrument in hand and perform a survey in accordance with safety regulations and the employer's Operating Procedures.

6.4 SPEC-300 Radiography System Break-Down Procedures

1. Survey the exposure device according to safety regulations and the employer's Operating Procedures

- to verify that the source is properly shielded.
2. To lock the source assembly, rotate the control adaptor operating lever clockwise approximately 45 degrees until rotation stops toward the "LOCK" position. The lever should point down vertically. The source assembly can no longer be unsecured by pushing down the release plunger.
3. Remove the guide tube from the outlet nipple.
4. Attach the safety plug to the outlet nipple and verify that it is securely fastened by tugging lightly after it is installed.
5. To lock the device, rotate the key counter-clockwise approximately 45 degrees toward the "Lock" position until rotation stops. The finger grooves on the key should be vertical and the key should spring outward slightly.

CAUTION!!

The finger grooves on the key must be vertical to lock the device. If it cannot be rotated completely, apply additional force by hand only. Do not use tools if it still cannot be rotated completely, the device has malfunctioned and must be taken out of service immediately. Refer to the employer's Operating and Emergency Procedures. DO NOT attempt to disassemble or repair the equipment.

6. Re-engage the transport lock by removing the retaining pin, sliding the lock fully to the right and installing the padlock through the transport lock knob.
7. Remove the control adaptor by rotating it counter-clockwise approximately 45 degrees and pull the adaptor off while cranking the drive cable forward a few inches.
8. Swivel the drive cable connector 90 degrees, push forward lightly to compress the spring in the source assembly connector, and pull the drive cable connector out of the side hole of the source assembly connector.
9. Retract the drive cable completely and install the dust cover into the control adaptor.
10. Install the lock cap on the control attachment boss at a 45 degree angle, rotate it clockwise until rotation stops. The lock cap should be positioned vertically.
11. Prepare the device for transportation and/or storage in accordance with applicable regulations, the employer's Operating Procedures, and the instructions in Section 9.0.

6.5 Emergency Response Procedures

An emergency exists when the radioactive source cannot be returned to the fully shielded position within the SPEC-300 exposure device. Any equipment malfunction or accident (including transport accident) that could cause the source to be unshielded should immediately be treated as an emergency.

6.5.1 Equipment Malfunctions and Accidents

The procedures in the employer's Operating and Emergency Procedures Manual must be strictly followed in an emergency. The emergency procedures recommended by the U.S. Nuclear Regulatory Commission consist of the following:

1. Quickly move away from the exposed source
2. **STAY CALM, DO NOT PANIC. STOP AND THINK!**
3. Establish or extend the restricted area.
4. Send for help and maintain surveillance.

DO NOT ATTEMPT TO RETRIEVE THE SOURCE OR ENGAGE IN EMERGENCY REPAIRS IF YOU HAVE NOT BEEN TRAINED AND AUTHORIZED TO DO SO. Be prepared to provide a detailed description of the incident to emergency response personnel. It is important for this information to be as accurate as possible for the safety of the emergency response personnel. SPEC is available to provide emergency assistance on a 24-hour basis. Phone 504-464-9471.

6.5.2 Fire

In the event of a fire, attempt to crank the source in and move the SPEC-300 to a safe area **ONLY** if this can be done without risk of personal injury. The SPEC-300 is designed to maintain shielding integrity when subjected to a fire at a temperature of 1475 degrees Fahrenheit for 30 minutes.

Immediately inform emergency response personnel about the potential radiation hazard. If the source is unshielded, warn fire personnel to remain outside of the restricted area and fight the fire from the greatest distance possible. Advise emergency personnel to refrain from entering the high radiation area unless required to remove injured individuals. Be prepared to monitor radiation levels if needed. Follow the above emergency procedures as much as possible.

6.5.3 Lost or Stolen Source

IMMEDIATELY notify the Radiation Safety Officer or other personnel as described in the employer's Operating and Emergency Procedures Manual if the source or exposure device is suspected to be lost or stolen.

7.0 SPEC-300 INSPECTION PROCEDURES

The NRC requires inspections by the user to determine if the radiography equipment is operating properly. The SPEC-300 system is manufactured with the highest degree of quality and durability. However, all equipment is subject to malfunctions due to extended use, abuse, neglect, and damage from accidents. Inspections must be performed by trained, qualified and authorized individuals.

7.1 Daily Inspection Procedures

It is recommended that a checklist be used to conduct the inspection and record the results. Any equipment that fails the Daily Inspection must be immediately taken out of service, reported to the Radiation Safety Officer, and replaced or repaired before use.

7.1.1 Survey Instrument

Each survey instrument must be carefully inspected in accordance with safety regulations and the employer's operating procedures. The survey instrument operability must be checked using check sources or other appropriate means. In addition to the radiation response check, the inspection should include an operability check in accordance with the manufacturer's recommendations. As a minimum, the check should include the following:

1. Battery condition
2. Calibration expiration date
3. Physical damage

7.1.2 SPEC-300 Exposure Device

1. Survey the device in accordance with employer's Operating Procedures using a calibrated and properly operating survey instrument with the lock cap and safety plug installed and the transport lock engaged.
2. Pull lightly on the safety plug, without retracting the spring-loaded knurled ring, to determine if it is firmly attached to the outlet nipple.

CAUTION!!

TO PREVENT UNNECESSARY RADIATION DOSE, DO NOT PLACE EYES OR FINGERS AT THE OUTLET NIPPLE OPENING.

3. Remove the safety plug and visually inspect the outlet nipple (from the side) for excessive wear, dents, cracks, or other obvious damage. Check to determine if the outlet nipple is loose.
4. Install the safety plug into the outlet nipple used for temporary storage (when the device is in use) to verify proper operation.
5. Pull on the lock cap to determine if it is firmly attached to the device.
6. Rotate the lock cap to determine if it pivots freely and that normal spring force exists.
7. Remove the lock cap and install it on the storage boss on the outlet end flange of the

- exposure device to verify proper operation.
8. Visually inspect the control adaptor attachment boss to check for cracks, dents, wear or other obvious damage.

CAUTION!!

An excessively worn control adaptor boss could cause a misconnect condition to exist (whereas a control adaptor could be attached to the device without connecting the drive cable connector to the source connector.) See Section 7.1.7, Control Assembly Adaptor to determine if this condition exists. If so, the equipment must be removed from service immediately.

9. Visually inspect the lifting eyes and tie down holes for cracks and other obvious damage.
10. Visually inspect to verify that the nameplate, source tag, and all caution and warning labels are completely legible.

7.1.3 Source Assembly Connector

1. Visually inspect to ensure that the source assembly connector is not cracked, excessively worn, or otherwise damaged.
2. Visually inspect the source assembly connector to check for foreign matter such as dirt, grease and grit. Use a brush or cloth to apply any mild cleaning solvent as needed for the type of foreign material to be removed. Excess residue should be wiped off. Aerosol spray solvents should be used with caution to avoid spraying into the device.
3. Push the connector piston to verify that it is free of foreign material and corrosion and also to check that normal spring force exists.
4. Attach the drive cable connector to the source assembly connector. It should attach securely and rotate freely.
5. Swivel the drive cable connector in the direction of the slot in the end of the source connector and visually estimate the arc of swivel. The connector should swivel approximately 90 degrees in one direction and approximately 40 degrees in the other.

CAUTION!!

THE INSPECTOR SHOULD WASH HANDS THOROUGHLY AFTER HANDLING THE CONNECTOR TO REMOVE ANY SOLVENTS AND POTENTIAL CONTAMINATION.

7.1.4 Control Assembly

1. Roll the control assembly into a couple coils, approximately 3 foot diameter. Remove the dust cover and slowly crank a few feet of drive cable out (onto a clean surface) and back in to determine if there is unusual resistance to cranking. Unusual resistance indicates damaged or dirty equipment.
2. Visually inspect the control conduits (sheaths) for dents, cuts or other damage.
3. Manually check the conduits for loose, broken or damaged fittings.

7.1.5 Pistol Grip

1. Visually check the control pistol housing for loose components and obvious defects, such as missing screws, bent or broken handle and crank arm.
2. Visually inspect to verify that the "Expose" and "Retract" markings are clearly legible.
3. To check the gear for excessive wear, leave the dust cover secured to the control adaptor and attempt to crank forward with moderate force. If the drive cable "skips" over the gear, the control assembly must be removed from service.

7.1.6 Drive Cable and Drive Cable Connector

The drive cable and connector is VERY critical to safety. Extra care should be taken when inspecting them. If the connector or drive cable is defective, it can cause a variety of equipment malfunctions and hazardous conditions. Inspect the drive cable and connector daily. This inspection should include the connector ball, neck, swage area, and approximately 12 inches of drive cable closest to the connector. The inspection should verify that the connector and cable meets the criteria given below. If the drive cable connector or the drive cable violates any of the following criteria, it should be removed from service immediately.

Inspection Instructions:

1. Manually inspect the connector swage area by manually attempting to twist the drive cable connector to verify that it is firmly attached to the drive cable.
2. Manually inspect the drive cable for flexibility and excessive rust by bending the last 6 inches of drive cable in to a "U" shape approximately 3 inches wide. When the drive cable is released, the end of the drive cable should spring back in its original straight shape. Failure to spring back most of the way (e.g. less than 30 degrees) indicates that corrosion or other abnormality has reduced the flexibility of the drive cable. If the cable springs back to essentially straight configuration it provides visual evidence that the cable is sufficiently flexible.
3. Visually inspect the drive cable for loose, bent, elongated, kinked, broken, or abnormally deformed wire strands.
4. Visually inspect the connector ball for signs of heavy wear.
5. Visually inspect the connector neck to ensure that it is not bent or cracked. If the connector neck is bent more than 10 degrees it should be replaced. A scaled illustration is provided below which illustrates a connector bent at 10 degrees.

Caution!!

Do not straighten a bent connector neck. Bending can crack and weaken the neck.

7.1.7 Control Assembly Adaptor

- | | |
|--|--|
| <ol style="list-style-type: none"> 1. Visually inspect the O-ring 2. Manually check the rotates freely and that the 3. Using light force, attempt | <p>for cracks, cuts, breaks and deformities.
operating lever to determine if it slides and spring is undamaged.
to install the control adaptor on the exposure</p> |
|--|--|

device with the drive cable and source assembly disconnected. If the adaptor can be installed, a misconnection condition has occurred. Remove the equipment from service immediately. (Also see Section 7.1.2 (8) which explains Control Attachment Boss wear.)

7.1.8 Guide Tube

1. Visually and manually inspect the guide tube for kinks, dents and cuts. Slide the hand along the length of the guide tube to feel for damage.
2. Visually and manually check the guide tube for loose, broken or damaged fittings.
3. Manually verify that threaded fittings, such as exposure heads (end piece) and connection fittings, are firmly attached.
4. Attach the guide tube to the outlet nipple. Verify that it is securely installed by attempting to remove it by applying a light pull by hand.
5. Verify that the collimator is fully and securely attached to the end of the exposure head (end piece).

7.2 Quarterly Inspection Procedures

The Quarterly Inspection is a detailed inspection to determine if repairs are required. This inspection must be conducted on a quarterly basis and any time there is an indication of a malfunction or damage. Inspections should be performed by the Radiation Safety Officer or other trained and qualified individuals authorized by the licensee. It is recommended that a checklist be used to conduct the inspection and record the results. Any equipment that fails the Quarterly Inspection must be immediately taken out of service, repaired before use, or replaced.

The Quarterly Inspection must include the steps described in the Daily Inspection Procedures, Section 7.1, the SPEC-300 System Operational Check, Section 7.2.6, any additional inspection requirements described in the employer's Operation Procedures Manual, and the additional quarterly inspection steps described here.

7.2.1 Survey Instrument

Perform Daily Inspection, Section 7.1.1.

7.2.2 SPEC-300 Exposure Device

Perform Daily Inspection, Section 7.1.2.

7.2.3 G-70 Source Assembly Connector



Perform Daily Inspection, Section 7.1.3

7.2.4 Control Assembly

Perform Daily Inspection, Sections 7.1.4 through 7.1.8. Perform visual inspections using a 5x magnifying

glass. 5x magnifying glasses are available from SPEC upon request. Contact SPEC Sales Department at 504-464-9471. Perform this check for misconnect prevention.

Place the opening on the gauge over the "Boss Ears" on the camera where the control adaptor hooks to the camera. The tool should stay on a 30 to 45 degree angle. It should not drop straight up and down (vertically). If it does, the boss is worn on the camera and the camera will have to be sent in to SPEC in order to replace the Boss.

<p>Place on the same not does</p>		<p>the "Male" opening of controls. result, move turn in the adaptor</p>		<p>end of the tool into the the Control Adaptor You should have the where the tool does much if at all. If it Control Adaptor, the will need to be</p>
---	--	---	---	--

replaced on the controls.

7.2.5



Guide Tube

Perform the Daily Inspection, Section 7.1.9. In addition, check for internal debris, obstructions and damage by sliding a dummy source assembly through the entire length of the guide tube. Use

gravity only, do not push. If a dummy pigtail is not available, a ball or short rod with a 3/8" diameter should be used.

NOTICE

If internal cleaning is needed, use a wire and cloth with mild solvent to clean. Do not use lubricants. DO NOT flush with liquids or use compressed air. These methods can cause trace amounts of Cobalt 60 or depleted uranium contamination to be released. Precautions should be taken to prevent exposure to the hands, and/or ingestion or inhalation.

7.2.6 SPEC-300 System Operational Check

The following SPEC-300 Exposure Device Operational Check Procedures, should be conducted AFTER the quarterly inspection of the individual equipment items have been conducted and all required repairs have been completed. In addition to the Quarterly Inspection, the operational check must be performed each time the ASM/Lock Module is replaced.

Currently there are no source changers authorized for use with the SPEC-300 device or the G-70 source model. The following instructions are used to verify the operation of only those mechanical safety features which are able to checked while the source remains installed inside the device.

Conduct the Operational Check in the EXACT sequence of steps described below. Start with the system as prepared for transport (with locked with safety plug and lock cap installed and the transport lock engaged.) To prevent inadvertent release of the source assembly from the device, the transport lock must remain engaged and padlocked and the safety plug installed during the entire operational check. If the device fails ANY of the following checks, remove the device from service and notify SPEC for assistance.

1. Ensure that the transport lock is engaged by sliding it fully to the right and is secured by a padlock (installed through the lock hasp; See illustrations on drawings 19B003 and 190900). Verify that safety plug is securely installed in the outlet end (nipple) of the device.
2. Attempt to unsecure the source assembly by depressing the release plunger down completely. The release plunger should spring back up when released.
3. Remove the lock cap.
4. Attempt to attach the control adaptor to the device WITHOUT connecting the drive cable to the dummy source assembly. The control adaptor MUST NOT be able to attach to the device.
5. Connect the drive cable connector to the source assembly connector and attach the control adaptor to the device.
6. Install the device key, push in and rotate clockwise approximately 45 degrees to unlock the device. Attempt to unsecure the source assembly by depressing the release plunger down completely. The release plunger should spring back up when released.
7. Push the operating lever into the device and rotate counter-clockwise approximately 45 degrees to unlock the source assembly.
8. Attempt to rotate the device key counter-clockwise to lock the device. The key should not rotate.

9. Depress the release plunger down completely. It should remain "latched" down when released.

NOTE

Although the device and source locks are disengaged, the source assembly cannot be inadvertently removed from the device. It is secured by the transport lock and the safety plug in accordance with Step 1 above.

10. Rotate the operating level clockwise. The release plunger should pop up. (The source lock is now engaged with the source assembly.)
11. Rotate the device key counter clockwise to engage the device lock and remove key. The key should automatically push (spring) out of the device.
12. Disconnect the controls and install the lock cap.
13. Ensure that the transport lock is secured by a padlock and return the device to storage.

8.0 SPEC-300 MAINTENANCE AND REPAIR PROCEDURES

8.1 General

Although routine inspection and maintenance are required by regulations (quarterly), there are no quarterly maintenance requirements for the SPEC-300 exposure device to comply with the warranty conditions for the product. Maintenance and repairs of the SPEC-300 and associated equipment must be done on an as-needed basis in response to daily and quarterly inspections and malfunction reports from the workers. The user should take precautions to protect against exposure to cleaning solvents, if used, and potential radioactive contamination when performing maintenance and repairs.

Maintenance should be performed by the Radiation Safety Officer or other trained and qualified individual authorized by the licensee. Due to the complexity of some radiography equipment, the licensee must be authorized to perform repairs. It is recommended that licensees consult the NRC, Agreement State licensing agency or other National authorities as applicable. SPEC is available to conduct inspection, maintenance and repairs of the SPEC-300 and all associated equipment. SPEC offers an Annual Maintenance Program for the SPEC-300. This program provides for a replacement ASM/Lock Module annually or as needed. More information regarding this program may be obtained by contacting the SPEC sales department at 504-464-9471.

Any maintenance, repair, inspections, etc. which requires the removal of the source assembly from the device by the licensee is unauthorized. Pending development of a source changer authorized for use with the SPEC-300 device and the G-70 source model, the device must be returned to SPEC for activities (maintenance, repair, inspections, etc.) that require removal of the source assembly from the device unless specifically authorized by the licensing authority.

8.2 Recommended Replacement Components

SPEC recommends that users keep one set of replacement components in stock. The set should consist of an ASM/Lock Module, Outlet Panel Assembly, Control Adaptor, Lock Cap, Safety Plug, Device Key and Special Tools.

8.3 Modifying, Repairing or Tampering with the Device

The SPEC-300 is an industrial radiography exposure device and a Type B(U)-85 radioactive material transport package. NRC and DOT regulations strictly prohibit unauthorized modifications, repairs, or tampering of the device.

8.4 SPEC-300 Exposure Device

The SPEC-300 Exposure Device is designed to limit the ingress of foreign matter such as mud, dirt, grease, sand and grit. The exterior of the device should be cleaned with the safety plug and lock cap installed. Hand cleaning with water, detergents and mild solvents may be used as needed. Do not use high pressure liquid or air cleaner systems to clean the device. Do not disassemble the device to clean.

8.5 ASM/Lock Module

The ASM/Lock Module is installed inside the lock box which is bolted to the lock end plate of the device. The ASM/Lock Module contains the exposure device lock, source assembly lock, and the automatic securing mechanism (ASM). It is easily replaced by authorized users without special training. It is removed from the device only with the use of special tools provided by SPEC. The ASM/Lock Module contains no user serviceable parts. It must be returned to SPEC or other licensee authorized to conduct maintenance and repair controlled by an NRC approved QA program.

8.5.1 Lock Box Removal

Since the ASM/Lock Module is installed inside the lock box (which is bolted to the device) it is necessary to first remove the lock box from the device to replace the ASM/Lock Module. The device is designed so this can be accomplished without removing the source assembly from the device and while the source remains locked in the fully shielded position during the procedure (transport lock). Remove the lock box using the by following steps in EXACT sequence. A properly operating and calibrated survey meter must be used during the entire procedure.

- 1) Begin the procedure with the source in the secured and locked position, the safety plug installed and with the controls removed from the device. Remove the lock cap since it will be necessary to visually monitor the source assembly connector during the removal procedure.
- 2) Ensure that the transport lock is engaged. Slide the transport lock fully to the right with the transport lock knob protruding through the right side of the device. A padlock must be installed through the knob to prevent the transport lock from inadvertently disengaging during the procedure. The source assembly is now locked and cannot move in any direction.
- 3) Using the special allen wrench (for lock box removal), remove all of the lock box flange bolts except for the two top corner bolts. (These two bolts will support the lock box and ASM/Lock Module until the final removal steps).
- 4) Install the device key into the lock at the bottom of the ASM/Lock Module and rotate clockwise, disengaging the device lock. The key will remain installed in the device lock.
- 5) Install a dummy operating lever into the source lock in the center of the ASM/Lock Module and rotate counter clockwise, disengaging the source lock. The operating lever will remain installed in the source lock.
- 6) Press the release plunger at the top of the ASM/Lock Module downward until it latches down, unsecuring the source.

Note:

Remember that although the device and source is unlocked and unsecured, the source cannot move out of the shielded position. It is being held in place by the transport lock that was engaged and padlocked in Step 2.

- 7) While manually supporting the lock box from falling, remove the final two bolts in the top corners of the lock box flange. Be careful not to allow the lock box to fall after the final two bolts are removed. Although the source cannot pull out of the device, it might be possible to damage the connector or pigtail assembly.
- 8) Carefully and slowly, in a horizontal direction, pull the lock box away from the lock end plate. As the lock box is being pulled away from the locked source assembly, the release plunger will pop up (as it mimics normal use). Ensure that the source assembly passes freely through the ASM/Lock Module while the lock box is being pulled away.
- 9) Once the lock box (and ASM/Lock Module) is removed from the device, survey to verify that the source has remained in the fully shielded position and that the radiation levels are safe.
- 10) The operating lever and device key (which still installed in the lock module) must be removed in order to remove the ASM/Lock Module from the lock box. Perform the following steps in order:
 - a) Insert a small diameter rod (between 1/16" and 1/8") into the control attachment boss approximately 1". (This will mimic the source assembly cable which is needed to engage the source lock).
 - b) Rotate the dummy operating lever clockwise, engaging the source lock. Remove the operating lever and small diameter rod from the control attachment boss.
 - c) Rotate the device key counter-clockwise, engaging the device lock and remove the device key. The ASM/Lock Module is now ready to be removed from the lock box.

8.5.2 ASM/Lock Module Replacement Procedures

These instructions must be read completely prior to performing any of the ASM/Lock Module replacement steps. Following the proper sequence of steps will ensure correct installation and prevent problems (such as misalignment) during the replacement procedure. Special Tools provided by SPEC are shown in Appendix 1, Drawings.

Special Tools Kit: Part Number B190785

8.5.2.1 ASM/Lock Module Removal

1. Using the hand driver and Torx tip, remove the six (6) screws from the ASM/Lock Module lid at the top of the lock box.
2. Using the special allen wrench (for ASM removal), remove the four (4) bolts from the lock box. The ASM/Lock Module is now loose inside the lock box.
3. Lift the ASM/Lock Module through the top of the lock box. (Note: It may be necessary to push the exposure device lock inward while lifting the ASM/Lock Module through the top of the lock box, allowing it to pass through the opening in the top of the lock box plate).

8.5.2.2 ASM/Lock Module Installation

1. Visually inspect the replacement ASM/Lock Module to verify that it is in the locked position, with the key slots in the exposure device lock vertical. See lock orientation drawing provided in Appendix 1, Drawings.
2. Remove the four bolts from the replacement module. Protect the anti-seize compound (which is already applied to the bolt's threads) from dirt and other debris.
3. Insert the replacement lock module into the top of the lock box.
4. Align and insert the four bolts through the lock box end plate into the lock module. Hand tighten to protect against cross-threading.

IMPORTANT!

Visually, verify the alignment between the lock module and the lock box end plate by looking into the operating lever hole. The slotted operating lever hole in the lock box must be aligned with the slotted source assembly lock on the lock module. Even minor misalignment may cause difficulty rotating the operating lever when attempting to unlock the source assembly.

5. Firmly tighten the four bolts using the special allen wrench.
6. Clean and install the six module lid screws into the top of the exposure device using the hand driver and Torx tip.
7. Install the device key into the lock at the bottom of the ASM/Lock Module and rotate clockwise, disengaging the device lock. The key will remain installed in the ASM/Lock Module.
8. Install a dummy operating lever into the source lock in the center of the ASM/Lock Module and rotate counter-clockwise, disengaging (opening) the source lock. The dummy operating lever will remain installed in the ASM/Lock Module.

Note:

If the operating lever or exposure device lock is difficult to rotate, this is an indication that the lock module was not properly aligned with the lock box. Loosen all ten fasteners and repeat steps 4 through 8 (above).

IMPORTANT!!

DO NOT PRESS THE RELEASE PLUNGER DOWN. (See Step 9a below.)

9. Carefully and slowly, re-install the lock box to the lock end plate by:
 - a. Aligning the source assembly (connector) with the opening in the ASM. (Note: if the release plunger is latched down, the source will not be able to pass through the ASM).
 - b. Horizontally, push the lock box flush with the lock end plate, aligning the lock box flange holes with the bolt holes in the lock end plate. The source assembly connector should be protruding through the control attachment boss approximately 1/8".
 - c. Install all 13 flange bolts and hand tighten to prevent cross threading. After all 13 bolts are installed, tighten using the special allen wrench.
10. Rotate the dummy operating lever clockwise, engaging the source lock. Remove the

- dummy operating lever.
11. Rotate the device key counter-clockwise, engaging the device lock. Remove the device key.
 12. Install the lock cap on the control attachment boss.
 13. Perform the SPEC-300 Operational Check referenced in Section 7.2.6 of this operating manual to verify that the replacement module was installed properly and that all exposure device functions are normal.

8.6 Outlet Panel Assembly

The Outlet Panel Assembly must be replaced as needed due to wear or damage. No routine maintenance is required other than to keep clean. Replacement is expected to be required every two to five years. If the outlet nipple must be replaced, it is necessary to replace the assembly. The outlet nipple cannot be removed by the user. A special tool is provided by SPEC to replace the panel. It is recommended that access to the special tool be controlled by the Radiation Safety Officer.

NOTICE

The temporary storage outlet nipple for the safety plug when the device is in use is NOT a replacement for the outlet nipple in the Outlet Panel Assembly.

CAUTION!!

The replacement of the Outlet Panel Assembly may be accomplished without removing the active source from the device. However, it is recommended that the source be removed from the device and stored in a temporary storage container to reduce the radiation dose to the fingers during the replacement of the assembly. If this is not practical, replace the assembly with the safety plug installed. This will reduce scatter radiation dose to the fingers and also ensure proper positioning of the assembly. Avoid placing eyes and fingers over or near the S-tube opening during the replacement of the assembly.

8.6.1 Outlet Panel Assembly Replacement Procedures

1. Remove the four (4) security screws using the special tool provided.
2. Thoroughly clean the screws of any dirt, grit or foreign matter.
3. Install the replacement Outlet Panel Assembly with the safety plug installed.
4. Once the four (4) tamper-resistant screws have been cleaned, insert and tighten into the outlet end plate using the special tool provided.

NOTICE

DO NOT REPLACE THE FOUR (4) TAMPER-RESISTANT SCREWS WITH ANY OTHER TYPE OF FASTENER. THE SPEC-300 IS LICENSED AS A TYPE B(U)-85 TRANSPORT PACKAGE AND MODIFICATIONS ARE PROHIBITED.

8.7 Lock Cap, Safety Plug, Key and Control Adaptor

These parts should be cleaned as needed to remain free of dirt, grease, grit and other foreign matter. It may be necessary to flush foreign matter from these components to provide proper operation. This may be done

by using a brush, compressed air, pressurized water, detergent bath, or by spraying the component with a mild, aerosol, cleaning solvent. Aerosol solvents should be used with caution to prevent spraying into any opening of the SPEC-300 exposure device. Any excess or residue water or cleaning fluid should be removed.

The control adaptor and key have a rubber O-ring seal to limit ingress of foreign material. The seals must be replaced annually or more often if a visual inspection detects cracks or other damage. The old O-ring can be removed without the use of special tools. The replacement O-rings should be installed by hand to avoid damage by the use of sharp tools.

8.8 Radiation Profile Surveys

A survey should be performed on a quarterly basis to determine if the SPEC-300 exposure device meets the radiation level limits specified in ANSI N432-1980. The radiation levels must not exceed 200 mR/hr at the surface of the device and 5 mR/hr at 1 meter from the surface of the device when extrapolated to 300 curies. By using a calibrated and properly operating survey meter, measure the radiation levels by scanning the entire surface of the device. Record the highest level at each surface. Survey at one meter from the highest readings at each surface. Extrapolate the readings to 300 curies. Determine if the adjusted readings exceed the regulatory limits or the levels recorded on the QA Inspection Certificate when the device was manufactured. Notify the Radiation Safety Officer if any discrepancies are detected.

8.9 G-70 Source Assembly

REPAIRS MAY NOT BE PERFORMED TO THE SOURCE ASSEMBLY, INCLUDING THE CONNECTOR, BY THE USER. DEFECTS OR MALFUNCTIONS MUST BE REPORTED IMMEDIATELY TO THE RADIATION SAFETY OFFICER. The connector should be cleaned with a brush and mild cleaning solvent as needed to remove foreign material.

8.10 Control Assembly Maintenance and Repair

Replacement parts and components are available from SPEC. Unauthorized replacement parts should not be used. It is recommended that licensees consult the NRC or Agreement State licensing agency to determine which replacement parts from other manufacturers are authorized for use. Parts that require a manufacturing process to install, such as fittings to be crimped, are not available as replacement components. Repairs that require a special process must be done under the control of an authorized Quality Assurance program.

8.10.1 Control Assembly Disassembly

This section provides step-by-step procedures to disassemble and clean the control assembly. It is recommended that these procedures be conducted on a quarterly basis and any time maintenance or repairs are required. The Daily Inspection Procedures, Section 7.1.4 through 7.1.7 and the SPEC-300 System Operational Check, Section 7.2.6, should be performed after this procedure.

1. Remove the drive cable from the control assembly by cranking it out until it automatically

- stops.
2. Cut off the tie wraps or tape and remove any fasteners that binds the conduits together.
 3. Unscrew the return conduit (bottom) from the pistol assembly. Conduits are attached to the pistol housing with a swivel adaptor to provide easy removal.
 4. After the return conduit is removed from the pistol assembly, retract the drive cable approximately 1 foot.
 5. Remove the spiral cable stop from the end of the drive cable by rotating the cable stop. The cable stop will unscrew from the coils (spirals) of the drive cable.
 6. Crank the drive cable forward until it passes completely through the gear. Manually pull the remaining drive cable through the control adaptor.
 7. Remove the drive conduit (top) from the control pistol by unscrewing.
 8. Unscrew the Control Adaptor from the other end of the conduit.
 9. Remove the three (3) screws from the side of the pistol assembly cover plate.
 10. Remove the cover plate from the control pistol. The crank arm, gear/shaft assembly, and cover plate bearing will be attached to the cover plate.
 11. Use a bearing puller to remove the bearing from the inside of the pistol housing, if needed.

8.10.2 Control Assembly Internal Component Inspection

Components that are not accessible to inspection on a daily basis should be closely inspected for wear and defects when the equipment is disassembled.

Control Pistol Assembly:

1. Verify that both bearings rotate freely.
2. Check that there are no broken teeth in the gear and that the gear is securely attached to the shaft.
3. The gear shaft should fit snugly into the cover plate bearing.
4. Inspect the drive cable path around the inside of the pistol housing wear ring for excessive wear that can allow the drive cable to skip on the gear when cranking out.

8.10.3 Control Assembly Cleaning Procedures

Use a brush and cloth with mild solvent to clean dirt, debris and foreign material off all components excluding the drive cable. Do not use lubricants. It is NOT recommended to spray with liquids or use compressed air. These methods are effective for cleaning, but they can cause trace amounts of Cobalt 60 or depleted uranium contamination to be released. It is very unlikely that the control conduits (sheaths) will require cleaning. However, if they must be cleaned, compressed air may be used only after taking all necessary safety precautions to protect against exposure, ingestion or inhalation of potential airborne contamination.

Maintenance of the drive cable is VERY CRITICAL to the safe operation of the system. Poorly maintained drive cables have been the cause of many system malfunctions which have lead to radiation overexposures. The following information is provided to users of Source Production and Equipment Company controls with Teleflex 5222 drive cables. The cleaning and lubrication

information was developed by Triumph Controls, Inc., North Wales, PA. SPEC makes no claims as to the suitability of this procedure and offers no other warranties except those expressly contained in SPEC purchase documents.

CLEANING AND LUBRICATION OF TELEFLEX 5222 CABLE

TOOLS/MATERIALS REQUIRED:

- Dow Corning DC33 Silicone Grease (Light Consistency)
- Houghton-quench G lubricant by Houghton International, Inc.
- A degreaser such as Varsol or Mineral Spirits
- Access to compressed air
- A hard bristle brush
- A galvanized 10/20 gallon tub for lubrication soaking.
- A galvanized 10/20 gallon tub or a standard parts washer for cleaning the cable
- Clean rags

SAFETY:

The degreaser specified is a combustible liquid and emits combustible vapors. Consult the Material Safety Data Sheets on the degreaser used as well as the other materials used in this procedure and take the necessary precautions for handling, breathing, ventilation and disposal.

PROCEDURE:

New Cable:

Before inserting the drive cable into the drive conduit, lubricate the cable with Dow Corning DC33 Silicone Grease (Light Consistency). The grease will be applied by hand and should fill approximately 1/3 of the space between the core and the spiral wrap. Remove excess by running the drive cable through a clean hand held rag.

Used Cable:

Follow the following steps for inspection, cleaning and lubricating:

Disassemble the controls and remove the drive cable from the conduit. Visually inspect and reject the cable for damage such as unwinding, nicks which would cause a stress point or excessive rust which would cause embrittlement. Check for embrittlement/flexibility and stress points by curling at any point suspected into a 3" diameter coil. Anywhere along the length of the cable should pass this test without bending or kinking. A light coat of surface rust is acceptable provided the

flexibility is not affected.

Cables which are acceptable should be coiled and placed into a cleaning tub. Pour degreaser into the cleaning tub. Fill the tub enough to cover the drive cable plus ¼ inch. Let the cable soak in the degreaser for approximately 1 hour, shaking the cable vigorously every 15 minutes to dislodge dirt and work the degreaser into the cable. Run a stiff bristle brush over the cable to dislodge any loose particles. Dip the cable back into the degreaser and agitate it vigorously for one minute. Lay the cable out on a flat surface and dry it thoroughly with compressed air.

Coil the cable and place it into the galvanized lube tub. Pour enough Houghto-quench G into the tub to completely cover the drive cable. Soak the cable in the lubricant for at least ¼ hour. Remove the coil of cable and suspend it above the tub for at least 4 hours, to drain the excess lubricant. Excess lubricant may also be spun out of the cable by use of a centrifuge for 3 minutes. Blow Excess oil from cable using oil free air, not exceeding 25 psi. Wipe cable with a dry, clean, lint free cloth.

Lubricate the cable with Dow Corning DC33 Silicone Grease (Light consistency). The grease will be applied by hand and should fill approximately 1/3 of the space between the core and the spiral wrap. Remove excess grease by running the drive cable through a clean hand held rag.

8.10.4 Control Re-assembly Procedure

1. Slip the bearing back into the pistol housing.
2. Install the gear/shaft assembly and cover plate onto the pistol housing.
3. Using the three (3) stainless steel screws, attach the cover plate to the pistol housing.
4. Screw the drive conduit (top) into the pistol housing (swivel adaptor) until it is firmly attached.
5. Attach the control adaptor to the opposite end of the top conduit.
6. Install the drive cable through the control adaptor and top conduit.
7. When the drive cable reaches the pistol housing, verify that the gear teeth mesh (align) with the end of the drive cable.
8. Crank the drive cable back until the drive cable feeds through the bottom side.
9. Install the cable stop onto the end of the drive cable by rotating the cable stop. Position the cable stop between ¼" and 5/8" past the end of the drive cable.
10. Attach the bottom conduit to the pistol housing (swivel adaptor).
11. Crank the drive cable in completely.
12. Using tie wraps or some other method, attach the two conduits to each other, side by side. Space the tie wraps approximately 18" apart.

8.11 Guide Tube

See Daily Inspection Procedures, Section 7.1.8.

Replacement of fittings that are attached directly to the guide tube by a manufacturing process such as crimping should be installed by the manufacturer or other licensee authorized by the NRC or Agreement State licensing agency.

9.0 TRANSPORTATION PREPARATIONS

9.1 Procedures for Preparing and Loading the Package

Training of personnel who prepare, transport, and offer for transport hazardous material shipments, including the model SPEC-300, is required pursuant to 49 CFR 172.700 and Section 10 of the Louisiana Radiation Regulations. The source assembly is loaded into the model SPEC-300 at the SPEC facilities under the provisions of Louisiana Radioactive Material License LA-2966-L01 in accordance with the procedures and radiation protection standards established under that license.

9.1.1 General Package Inspection

Visually inspect the model SPEC-300 to determine if it is in unimpaired condition for the shipment. The model SPEC-300 should be inspected to verify that it is not damaged, that the lock operates properly, that the source assembly (pigtail) is securely locked in the package, and that the safety plug and lock cap are securely positioned. Verify that the package identification plate is present and legible, which identifies the package as a model SPEC-300 and displays the Certificate of Compliance identification number.

9.1.2 Packaging

Verify that the source assembly is properly secured and locked in the model SPEC-300. The safety plug and the lock cap must be firmly attached. Verify that a tamper seal is installed through the lock cap knob and the lock box. Measure the maximum surface radiation level and the maximum radiation level at one meter from the surface of the package. The maximum surface radiation level must not exceed 200 mrem/hr. Although it is permissible for the maximum radiation level at one meter from the surface of the package to not exceed 10 mrem/hr, the maximum radiation level at one meter from the surface of the SPEC-300 should not exceed 5 mrem/hr.

9.1.3 Outer Package Surface Contamination

Packages may not be shipped on a non-exclusive use basis with outer surface contamination levels exceeding the values below, and it is the shipper's responsibility to ensure that the following conditions are met. Regulations require that the non-fixed (removable) contamination on the external surfaces of the outer package being shipped on a non-exclusive use basis not exceed 10^{-5} $\mu\text{Ci}/\text{cm}^2$ ($0.4 \text{ Bq}/\text{cm}^2$ or $22 \text{ dpm}/\text{cm}^2$) averaged over 300 cm^2 of any part of the surface. This may be determined by measuring the activity on wipes taken from representative locations and the above criteria is assumed to be met if the activity on any sample averaged over the surface area wiped does not exceed 10^{-5} $\mu\text{Ci}/\text{cm}^2$ ($0.4 \text{ Bq}/\text{cm}^2$ or $22 \text{ dpm}/\text{cm}^2$). If the contamination on the surface of the outer package exceeds the above amount, it must not be shipped.

9.1.4 Transportation Requirements

The model SPEC-300 package must be properly marked, labeled and described on a shipping paper in accordance with U.S. Department of Transportation regulations. Placards will be offered to carriers transporting a Radioactive Yellow III labeled package. Shipping papers will be retained for one year in accordance with U.S. Department of Transportation regulations.

9.1.5 Type B Quantity Consignee Notification

Prior to each shipment of a model SPEC-300 containing more than, 10.8 curies Cobalt 60, the shipper shall notify the consignee of the dates of shipment and expected arrival.

9.2 Procedures for Receipt and Unloading the Package

9.2.1 Receiving the SPEC-300

1. Delivery, Pick Up and Acceptance from Carrier:

Regulations require that the consignee make arrangements to receive the model SPEC-300 when it is offered for delivery by the carrier; or must make arrangements to receive notification from the carrier at the time of arrival for pick up at the carrier's facility. The consignee must expeditiously pick up the model SPEC-300 upon receipt of notification from the carrier.

2. Receipt Survey and Inspection:

Before the delivered package is opened and as soon as practicable after receiving the model SPEC-300, but no later than three hours after it is received at the consignee's facility during normal working hours or within three hours beginning the next work day if received after normal working hours, the package must be monitored and inspected. The outside package, as received, should be inspected for any indication of damage to the model SPEC-300, and the maximum external radiation levels at the surface of the outside package and at one meter from the surface of the outside package must be measured and recorded. Dents and abrasions to the overpack, if used, (such as a 20 WC overpack) normally encountered in handling, loading and unloading are not generally considered evidence of damage to the model SPEC-300.

Since the sealed source in the model SPEC-300 is classified as special form radioactive material, it is not required to monitor the external surfaces of the outside package for removable contamination. SPEC recommends that the SPEC-300 System Operational Check Procedures in Section 7.2.6 be conducted before the first use of a new unit to verify that it was not damaged in transport.

3. Notification:

If the measured maximum radiation levels exceed 200 mrem/hr at the surface of the outside package or 10 mrem/hr at one meter from the surface of the outside package, the consignee must immediately notify the final delivering carrier, and either the agreement state radiation control agency, if applicable, or the NRC regional office having jurisdiction over the location where the package was received. It is also recommended that the shipper be notified. Care should be exercised in performing the survey to ensure that the radiation levels are measured at the proper distances, that the survey meter is calibrated and operating properly, and that the stated accuracy of the survey meter be considered.

4. Records:

Records of the receiving survey should be maintained for a period of three (3) years. These records should include at least:

- a. the date and time the package was received or picked up;
- b. the date and time it was monitored;
- c. the identification of package by serial number;
- d. identification of source by serial number, isotope and activity (includes date of measurement);
- e. identification of individual performing survey;
- f. identification of survey meter by serial number;
- g. maximum radiation levels at surface of outside package and at one (1) meter from surface of outside package; and
- h. corrective action and notification to carrier and regulatory agency, if applicable.

9.2.2 Unloading the SPEC-300

The consignee must establish written procedures for receiving the model SPEC-300 package in accordance with applicable NRC and agreement state regulations. Such procedures should provide for inspection, monitoring, notification and records. The model SPEC-300 package becomes an industrial radiography exposure device after receipt by the licensed industrial radiography user. The source assembly is temporarily removed and then returned to the exposure device frequently throughout its use in accordance with the licensed user's procedures and in accordance with applicable NRC or agreement state regulations.

9.3 Preparation of an Empty Package for Transport

Test to verify that the SPEC-300 does not contain a radioactive source (authorized source, unauthorized source, modified source, or a source capsule that has been removed from the source assembly) by the following method. This test should be performed by authorized and monitored personnel who have been trained in radiation safety and equipped with a properly operating survey instrument.

First, remove the safety plug and survey the open outlet nipple. The depleted Uranium shield is radioactive and will emit radiation even when no sealed source is installed in the package, but the

highest radiation level should not exceed approximately 0.02 mSv/hr (2 mR/hr). Second, remove the lock cap and visually inspect the package to verify that no source assembly connector is protruding. This will indicate that there is no source assembly installed. Third, attach a control assembly to the package and crank only the drive cable from the control assembly forward through and out of the package while monitoring the survey instrument for a radiation hazard. A detached source capsule or otherwise unauthorized source will be pushed out of the package by the drive cable being cranked through the package. An exposed source must be treated as an emergency. Fourth, attach a dummy connector or dummy source assembly to the end of the drive cable. Retract the drive cable fully, then disconnect and remove the control assembly from the package, and install the safety plug and lock cap. If a dummy connector was used it will be removed with the controls. If a dummy source assembly was used it will remain in the package and must be disconnected from the control drive cable to remove the controls.

The empty packaging contains approximately 500 pounds of depleted uranium and may be shipped as either labeled radioactive material package or as an excepted package, article manufactured from depleted uranium as required by applicable U.S. Department of Transportation regulations.

APPENDIX 1

DRAWINGS

190900
190901
190902
190903
190904
190905
190906
190907
190908
190909
190910
190911
190912
190911
150009
151208

Sc
S
MUTERS

REV | DESCRIPTION | DATE | APPROVED

1. PACKAGE OVERALL DIMENSIONS 14" X 15" X 26" NOMINAL

2. THE NAMEPLATE IS LOCATED ON THE BACK SIDE.

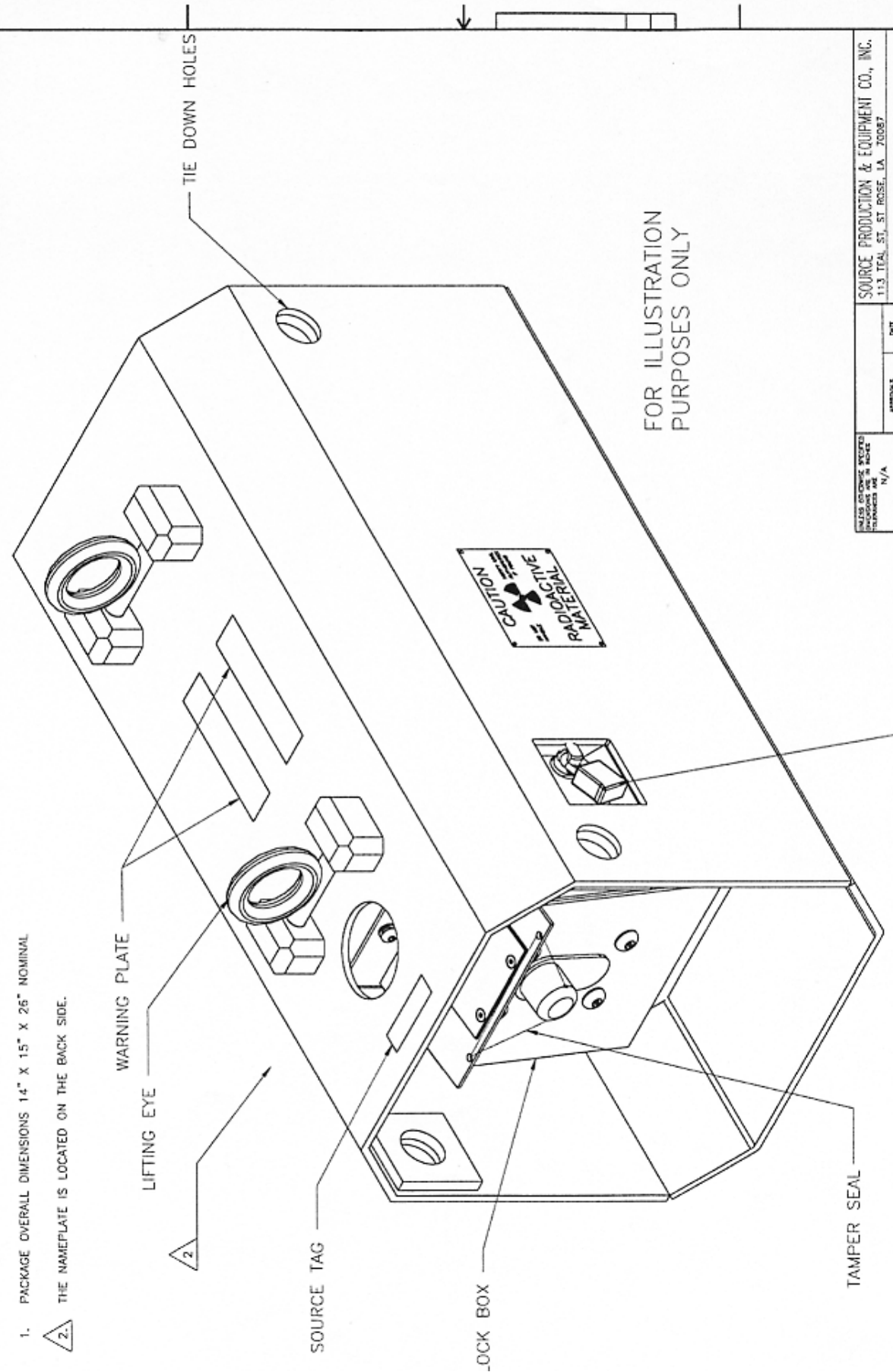

UNLESS OTHERWISE SPECIFIED
ALL DIMENSIONS ARE IN INCHES
TOLERANCES ARE
N/A

APPROVALS: _____ DATE: _____

SOURCE PRODUCTION & EQUIPMENT CO., INC.
113 TEAL ST. ST. ROSE, LA. 70087

Sc
SF

[REV] DESCRIPTION DATE APPROVED

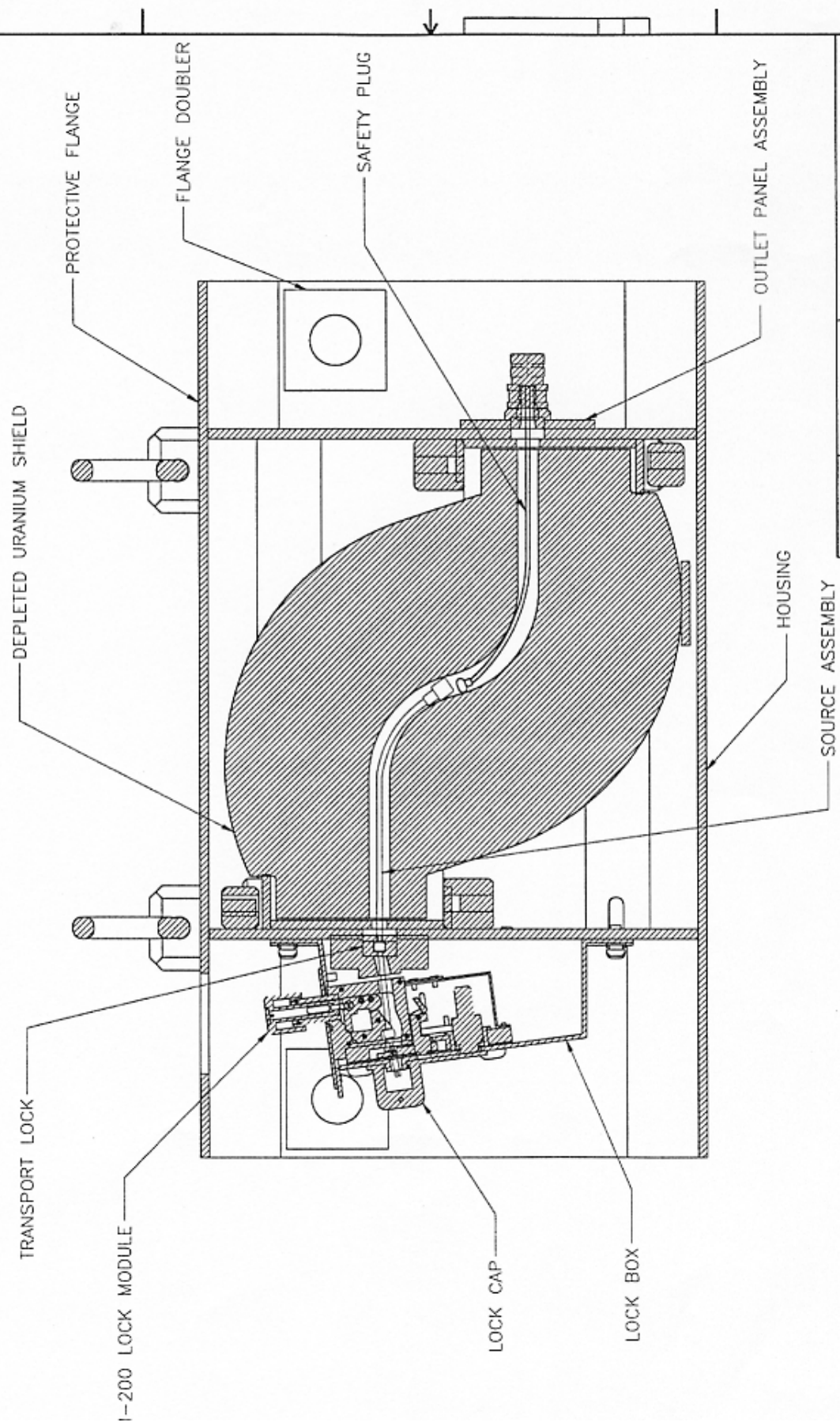

APPROVALS DATE

SALE DRAWING POCED
INSTRUMENTS ARE
N/A

SOURCE PRODUCTION & EQUIPMENT CO., INC.
113 TEAL ST. ST ROSE, LA 70087

REV | DESCRIPTION | DATE | APPROVED

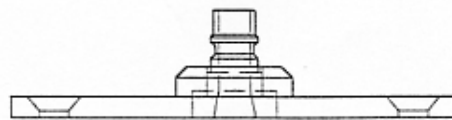
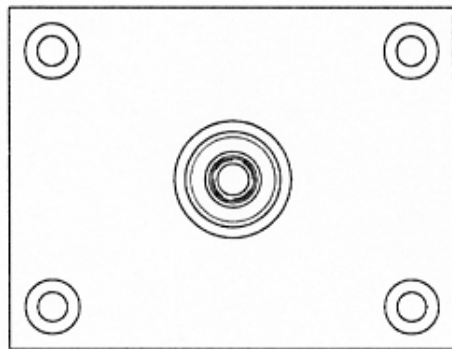

FOR ILLUSTRATION PURPOSES ONLY

UNLESS OTHERWISE SPECIFIED
 DIMENSIONS ARE IN INCHES
 TOLERANCES ARE N/A

APPROVED: _____ DATE _____

SOURCE PRODUCTION & EQUIPMENT CO., INC.
 113 1544 ST. ST ROSEL LA 70067

CONTROLLED COPY NO		
REV	DESCRIPTION	DATE

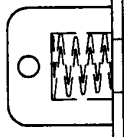
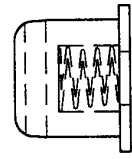
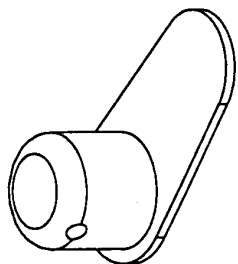

FOR ILLUSTRATION PURPOSES ONLY

MANUFACTURER'S DRAWING N/A		APPROVALS DRAWN: <i>[Signature]</i> CHECKED: <i>[Signature]</i> APPROVED: <i>[Signature]</i>		DATE 7/12/99
DO NOT SCALE DRAWING TREATMENT NONE		LOCK CAP ASSEMBLY, SPEC-300 USER'S MANUAL SET NO. C190903		REV 0
FINISH NONE		SCALE: 1/1 00084000		SHEET 1 OF 1
SOURCE PRODUCTION & EQUIPMENT CO., INC. 1113 TEAL ST. ST. ROSE, LA 70087				

CONTROLLED COPY NO		
REV	DESCRIPTION	DATE
		APPROVED

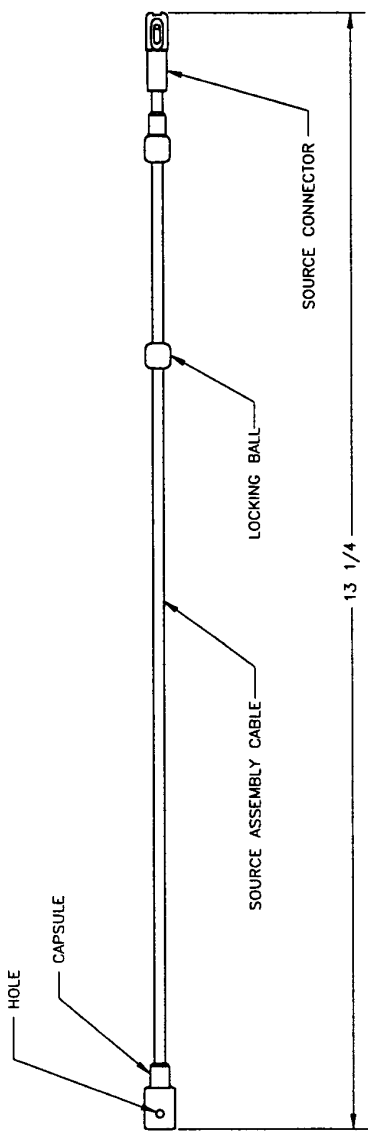
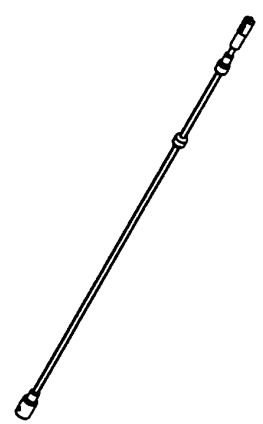

FOR ILLUSTRATION PURPOSES ONLY

SOURCE PRODUCTION & EQUIPMENT CO INC 113 TEAL ST, ST ROSE, LA 70087	
G-70 DUMMY SOURCE, SPEC-300 USER'S MANUAL	
DATE	7/12/99
APPROVALS	DATE
DESIGNED	7/12/99
CHECKED	7/12/99
APPROVED	7/12/99
SCALE: 1/1	00084200
SHEET 1 of 1	

CONTROLLED COPY NO		
REV	DESCRIPTION	DATE
		APPROVED

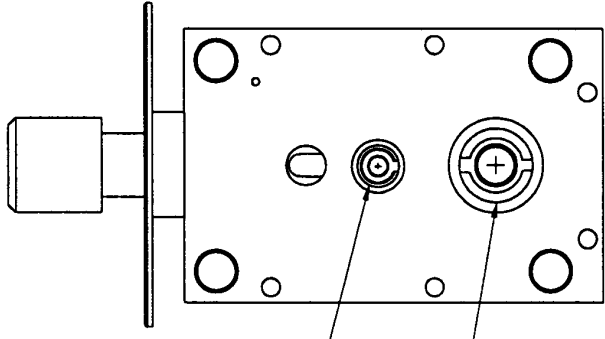
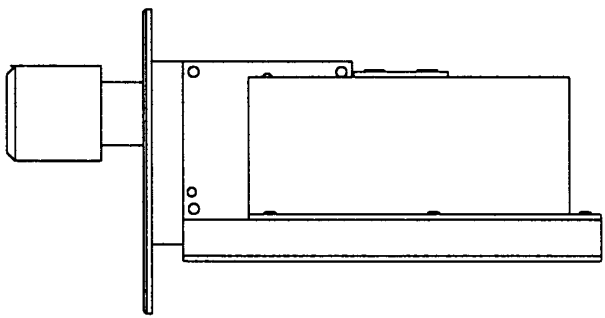

SOURCE ASSEMBLY LOCK
OPERATE USING CONTROL
ADAPTOR OPERATING LEVER

DEVICE LOCK
OPERATE USING
DEVICE KEY

FOR ILLUSTRATION PURPOSES ONLY

NOTE: SPECIAL TOOLS REQUIRED FOR
ASM/LOCK MODULE REPLACEMENT.

SOURCE PRODUCTION & EQUIPMENT CO., INC. 113 TEAL ST. ST. ROSE, LA. 70087	
APPROVALS DRAWN: [Signature] CHECKED: [Signature] APPROVED: [Signature]	DATE 7/12/98 7-13-98 7/13/98
DO NOT SCALE DRAWING TREATMENT NONE FINISH NONE	SIZE: 190905 SCALE: NTS SHEET 1 OF 1

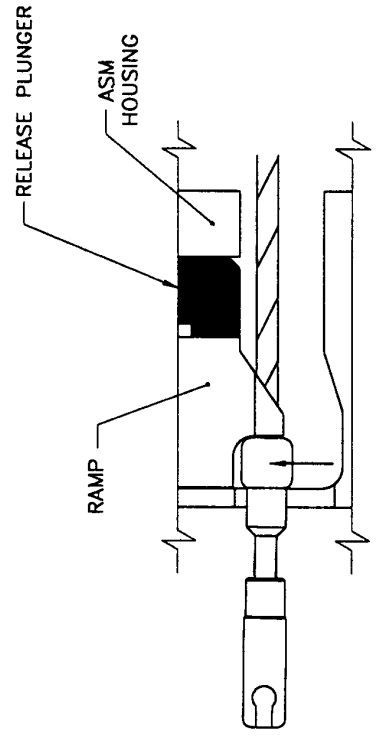

① SECURED

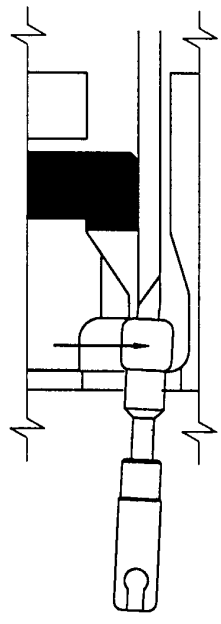

② UNSECURED
(RELEASE PLUNGER LATCHED DOWN)

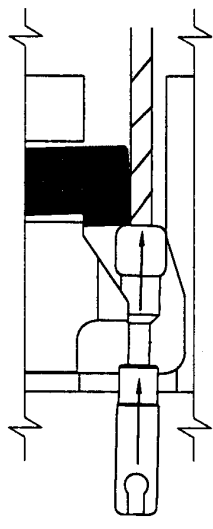

③ CRANKING FORWARD
(UNLATCHING RELEASE PLUNGER)

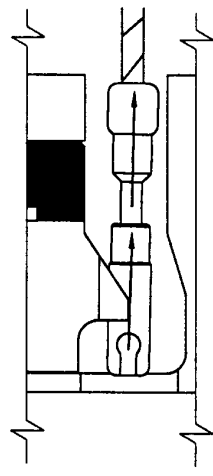

④ CRANKING FORWARD
(TO EXPOSE SOURCE)

FOR ILLUSTRATION PURPOSES ONLY

SOURCE PRODUCTION & EQUIPMENT CO., INC. 113 TEAL ST. ST. ROSE, LA 70087		DATE: 7/12/99	
OPERATION OF LM-200 ASM, SPEC-300 USER'S MANUAL		DWG. NO: 2-17-95	
SCALE: 1/1		REV: C 190906	
SHEET 1 OF 1		00084600	
APPROVALS:		DATE: 7/13/99	
DWGN: RAM	APPROVED: [Signature]	DATE: 7/13/99	
CHKD: [Signature]	APPROVED: [Signature]	DATE: 7/13/99	
DO NOT SCALE DRAWING	REWORK: NONE	PART: NONE	
UNLESS OTHERWISE SPECIFIED, DIMENSIONS ARE IN INCHES			
TOLERANCES: N/A			

CONTROLLED COPY NO		
REV	DESCRIPTION	DATE

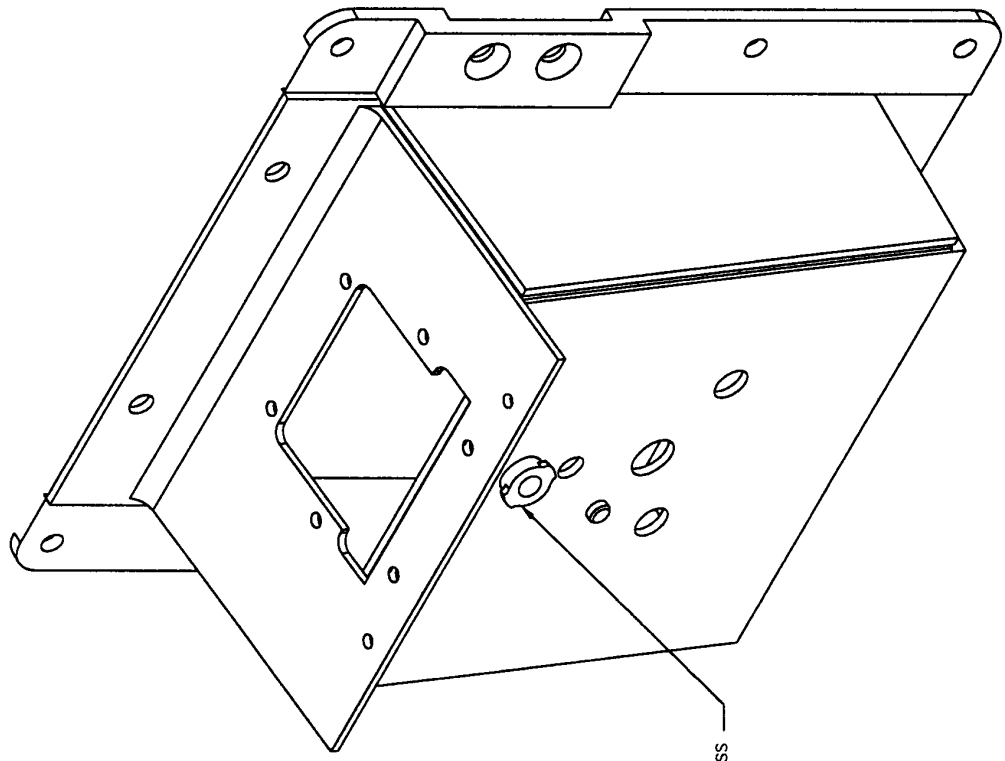

CONTROL ATTACHMENT BOSS

SOURCE PRODUCTION & EQUIPMENT CO., INC. 113 TEAL ST, ST ROSE, LA. 70087	
DATE 7/12/99	LOCK BOX SPEC-300 USER'S MANUAL
APPROVALS DRAWN: [Signature] CHECKED: [Signature] APPROVED: [Signature]	SIZE: [Signature] C 190910
UNLESS OTHERWISE SPECIFIED DIMENSIONS ARE IN INCHES N/A	SCALE: NTS 00085000 SHEET 1 OF 1
DO NOT SCALE DIMENSIONS TREATMENT: NONE FINISH: NONE	REV 0

FOR ILLUSTRATION PURPOSES ONLY

NOTES:

1. LETTERING AND TREFOIL SYMBOL TO BE EMBOSSED.
2. YELLOW BACKGROUND.
3. MAGENTA RADIATION SYMBOL.
4. BLACK LETTERING.

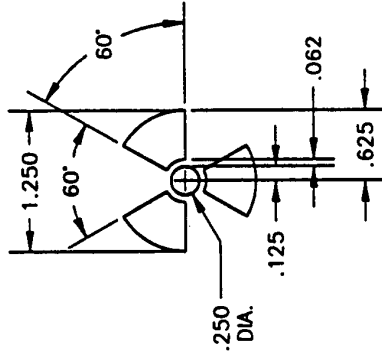
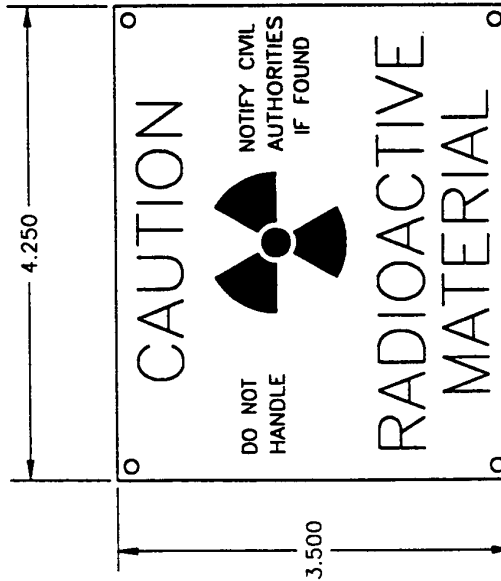

REVISIONS			
REV	DESCRIPTION	DATE	APPROVED

SOURCE PRODUCTION & EQUIPMENT CO, INC 113 TEAL ST, ST ROSE, LA 70087		TREFOIL -	
SPEC-300 USER'S MANUAL		SCALE: 1/1	
DATE: 7/12/09		SHEET 1 OF 1	
DRAWN BY: RJ		00085700	
CHECKED BY: [Signature]		190911	
APPROVED BY: [Signature]		B	
DATE: 7/13/09		0	
TOLERANCE: NONE		0	
FINISH: NONE		0	

CONTROLLED COPY NO

REVISIONS		
REV	DESCRIPTION	DATE

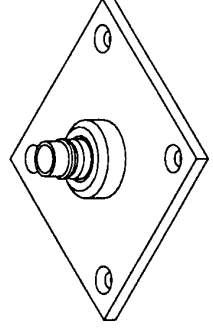

NOTES:
1. -1 SHOWN.

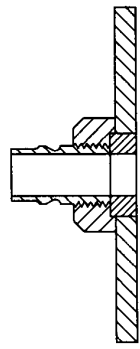
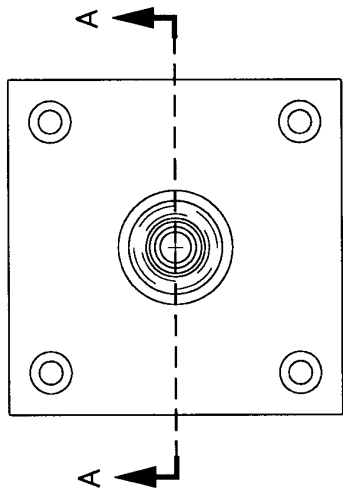

SECTION A-A

FOR ILLUSTRATION ONLY

UNLESS OTHERWISE SPECIFIED DIMENSIONS ARE IN INCHES TOLERANCES ARE	APPROVALS	DATE	SOURCE PRODUCTION & EQUIPMENT CO INC 113 TEAL ST. ST. ROSE, LA. 70087
	DRAWN	7/12/99	
DO NOT SCALE DIMMING	CHECKED	7/28/99	OUTLET PANEL
TREATMENT	APPROVED	7/28/99	SPEC-300 USER'S MANUAL
FINISH			SIZE
			C
			DWG NO. 190912
			REV 0
			SCALE: 1/1
			SHEET 1 of 1

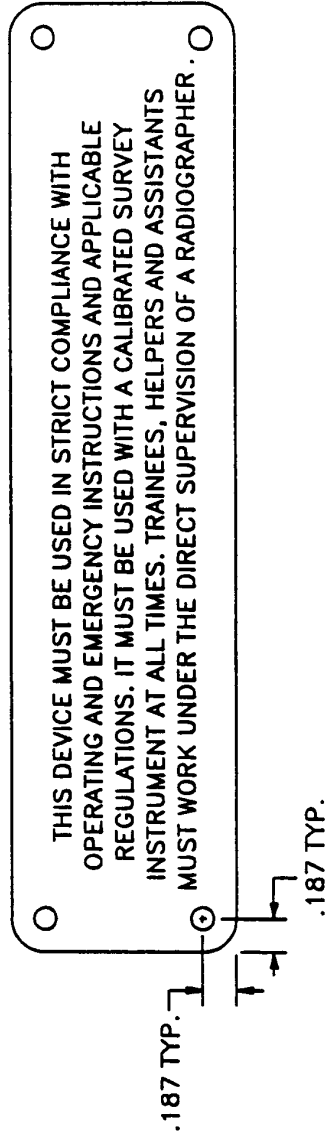
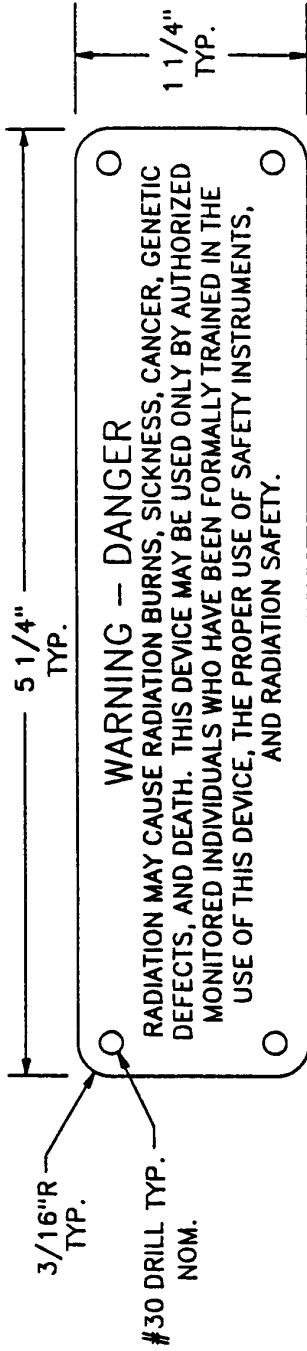

- NOTE 1: RED LETTERS ON METALLIC FINISH.
- NOTE 2: LETTERING TO BE ETCHED.
- NOTE 3: TITLE LETTERING: 0.135" HIGH, TEXT: 0.090" HIGH.
- NOTE 4: MAINTAIN A 0.187" BORDER.

MATERIAL: STAINLESS STEEL
1/32" NOMINAL PLATE THICKNESS

TOLERANCES (EXCEPT AS NOTED)		REVISIONS			SOURCE PRODUCTION & EQUIPMENT CO., IN	
#	DATE	DWG BY	APP'D BY	113 TEAL ST., ST. ROSE, LA. 70087		
DECIMAL	1	10-17-94	SB	RDD	SPEC-150 EXPOSURE DEVICE	
+/- N/A	2	10-25-94	SB	RDD	WARNING - DANGER LABEL	
FRACTIONAL	3	11-1-94	SB	[Signature]	DRAWN BY	JBMOORE
+/-	4				SCALE	1 TO 1
ANGULAR	5				CHK'D BY	K.C. 11-7-94
+/-					DATE	9-8-94
					APP'VD BY	R.D. DICHARRY
					Q.A. CLASS.	N
					DRAWING NO.	150009
					REV.	(3)

CONTROLLED COPY NO 3

REVISIONS	
REV	DESCRIPTION
(1)	INCORPORATED EDRF 041029-1.
	DATE 11/24/04
	APPROV [Signature]
	DATE 12/13/04
	APPROV [Signature]

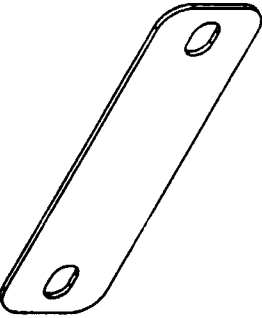

PROPRIETARY NOTICE: This document and the subject matter hereof are the property of Source Production & Equipment Co Inc and shall not be reproduced or copied or used for the purpose of manufacturing or sale of apparatus except by written permission of Source Production & Equipment Co Inc.

NOTES:

1. -1 SHOWN.
2. REMOVE ALL SHARP EDGES.
3. LETTERING TO BE BLACK, 1/16" VERTICAL CAPS.
4. LETTERING TO BE ETCHED, MINIMUM .002" DEEP.

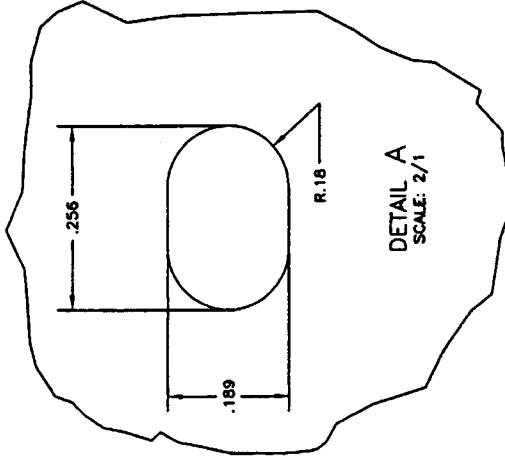
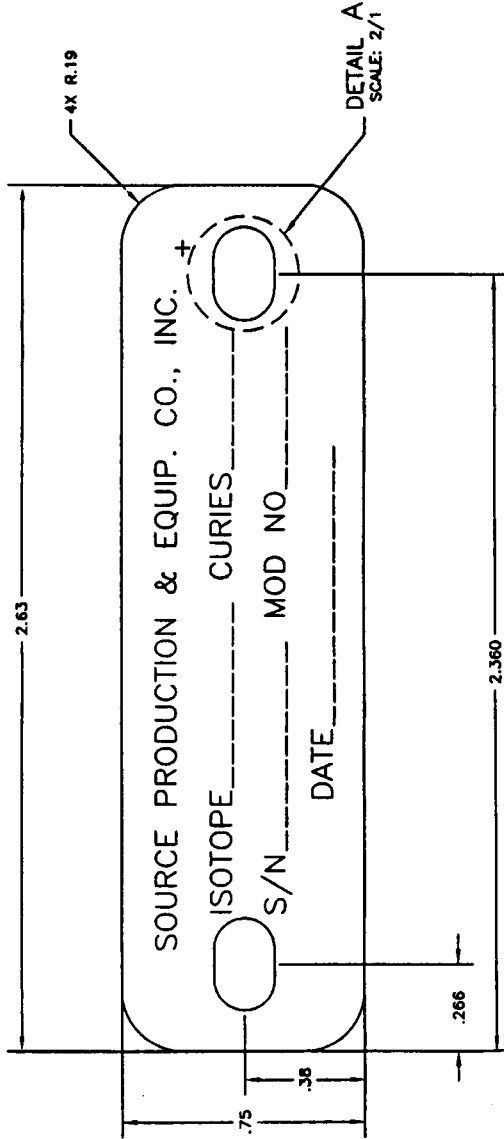

AR IN	OPT	SOURCE TAG	ALUMINUM
AR IN	OPT	-1	22 GA SHEE
AR IN	OPT	-3	300 SERIES C
QTY	UN	MANUF	IDENTIFYING NUMBER
			INDUSTRY OR NATIONAL SPECIFICATION

SOURCE PRODUCTION & EQUIPMENT CO.,	
113 TEAL ST. ROSE, LA. 70087	
DATE	9/2/92
APPROVAL	10/3/92
DESIGNED BY	10/3/92
DATE	10/3/92
SCALE	4/1
SHEET	1 OF 1

